



STEEL DECK INSTITUTE

---

# STANDARD PRACTICE DETAILS

MAY 2001

ADDENDUM 1 - FEBRUARY 2017

ADDENDUM TO STANDARD PRACTICE DETAILS, 2001 EDITION

Page 13 - Pour Stop Table. Replace page 13 with page 13.1.

Page 14 - Gage Closure at Girder. Replace page 14 with page 14.1.

Page 15 - Design Values for Studs. Replace page 15 with page 15.1.

COMPOSITE DECK DETAILS

## POUR STOP GAGE SELECTION TABLE

Slab Depth, in	Overhang, in												
	0	1	2	3	4	5	6	7	8	9	10	11	12
4.00	20	20	20	20	18	18	16	14	14	12	12	10	10
4.25	20	20	20	18	18	16	16	14	12	12	12	10	10
4.50	20	20	20	18	18	16	16	14	12	12	12	10	10
4.75	20	20	18	18	16	16	14	14	12	12	10	10	10
5.00	20	20	18	18	16	16	14	14	12	12	10	10	
5.25	20	20	18	16	16	14	14	12	12	12	10	10	
5.50	20	18	18	16	16	14	14	12	12	12	10	10	
5.75	20	18	18	16	14	14	12	12	12	12	10	10	
6.00	20	18	16	16	14	14	12	12	12	12	10	10	
6.25	18	18	16	16	14	14	12	12	12	10	10	10	
6.50	18	16	16	14	14	12	12	12	12	10	10	10	
6.75	18	16	16	14	14	12	12	12	10	10	10	10	
7.00	18	16	14	14	12	12	12	12	10	10	10	10	
7.25	16	16	14	14	12	12	12	10	10	10	10	10	
7.50	16	14	14	12	12	12	12	10	10	10	10	10	
7.75	16	14	14	12	12	12	12	10	10	10	10	10	
8.00	16	14	12	12	12	12	10	10	10	10	10	10	
8.25	14	14	12	12	12	12	10	10	10	10	10	10	
8.50	14	14	12	12	12	10	10	10	10	10	10	10	
8.75	14	12	12	12	12	10	10	10	10	10	10	10	
9.00	14	12	12	12	10	10	10	10	10	10	10	10	
9.25	14	12	12	12	10	10	10	10	10	10	10	10	
9.50	12	12	12	10	10	10	10	10	10	10	10	10	
9.75	12	12	12	10	10	10	10	10	10	10	10	10	
10.00	12	12	10	10	10	10	10	10	10	10	10	10	
10.25	12	12	10	10	10	10	10	10	10	10	10	10	
10.50	12	12	10	10	10	10	10	10	10	10	10	10	
10.75	12	10	10	10	10	10	10	10	10	10	10	10	
11.00	12	10	10	10	10	10	10	10	10	10	10	10	
11.25	12	10	10	10	10	10	10	10	10	10	10	10	
11.50	12	10	10	10	10	10	10	10	10	10	10	10	
11.75	10	10	10	10	10	10	10	10	10	10	10	10	
12.00	10	10	10	10	10	10	10	10	10	10	10	10	

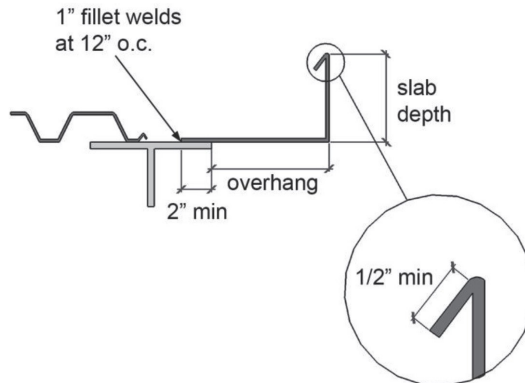

Type	Thickness Inches
20	0.0358
18	0.0474
16	0.0598
14	0.0747
12	0.1046
11	0.1196
10	0.1345

## GIRDER FILLERS

Slab Thickness (in)	Span (in)	Type	Thickness (In)
≤ 12	≤ 5	20	0.0358
	5.1 ≤ L ≤ 5.5	16	0.0598
	5.6 ≤ L ≤ 9	14	0.0747

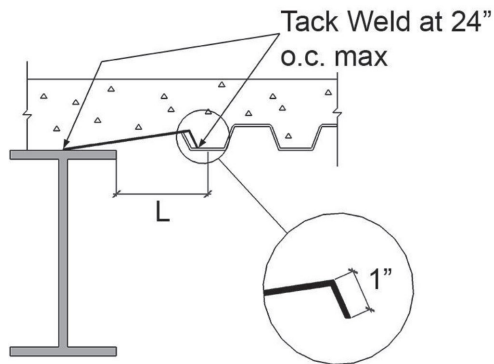

COMPOSITE DECK DETAILS

## SHEAR CONNECTOR (STUD) NOMINAL STRENGTH (LBS)

Deck condition		Stud diameter (inches)	Normal weight concrete		Light weight concrete		
			$w_c = 145 \text{ pcf}$		$w_c = 110 \text{ pcf}$		
			$f'_c$ 3000 psi	$f'_c$ 4000 psi	$f'_c$ 3000 psi	$f'_c$ 4000 psi	
No deck		3/8	5260	6530	4280	5310	
		1/2	9350	11600	7600	9430	
		5/8	14600	18100	11900	14700	
		3/4	21000	26100	17100	21200	
Deck Parallel to beam	$\frac{w_r}{h_r} \geq 1.5$	3/8	5260	5380	4280	5310	
		1/2	9350	9570	7600	9430	
		5/8	14600	15000	11900	14700	
		3/4	21000	21500	17100	21200	
	$\frac{w_r}{h_r} < 1.5$	3/8	4580	4580	4280	4580	
		1/2	8140	8140	7600	8140	
		5/8	12700	12700	11900	12700	
		3/4	18300	18300	17100	18300	
Deck Perpendicular to beam	Weak position studs per rib	1	3/8	4310	4310	4280	4310
			1/2	7660	7660	7660	7660
			5/8	12000	12000	12000	12000
			3/4	17200	17200	17200	17200
		2	3/8	3660	3660	3660	3660
			1/2	6510	6510	6510	6510
			5/8	10200	10200	10200	10200
			3/4	14600	14,600	14600	14600
		3	3/8	3020	3020	3020	3020
			1/2	5360	5360	5360	5360
			5/8	8380	8380	8380	8380
			3/4	12100	12100	12100	12100
	Strong position studs per rib	1	3/8	5260	5380	4280	5310
			1/2	9350	9570	7600	9430
			5/8	14600	15000	11900	14700
			3/4	21000	21500	17100	21200
		2	3/8	4580	4580	4280	4580
			1/2	8140	8140	7600	8140
			5/8	12700	12700	11900	12700
			3/4	18300	18300	17100	18300
		3	3/8	3770	3770	3770	3770
			1/2	6700	6700	6700	6700
			5/8	10500	10500	10500	10500
			3/4	15100	15100	15100	15100

Stud nominal strength calculated in accordance with AISC-360, Chapter I. Stud strong and weak position in deck ribs is defined in that Standard.