



**AMERICAN NATIONAL STANDARDS INSTITUTE/ STEEL DECK INSTITUTE**

**ANSI/SDI AISI S908-2017 (R2024)**

**Test Standard for Determining the Flexural Strength  
Reduction Factor of Purlins Supporting a Standing  
Seam Roof System**



## **DISCLAIMER**

The information presented in this publication has been prepared in accordance with recognized engineering principles but is for general information only. While it is believed to be accurate, this information should not be used or relied upon for any general or specific application without a review and verification of its accuracy and applicability by a Registered/Licensed Professional Engineer, Designer or Architect. Neither the Steel Deck Institute nor the author of any information contained in this publication makes any representation or warranty, expressed or implied, respecting any of the information contained in this publication, including, but not limited to, the accuracy, completeness, or suitability of such information for any particular purpose or use and the Steel Deck Institute and each such author expressly disclaims any and all warranties, expressed or implied, regarding the information contained in this publication. By making this information available, neither the Steel Deck Institute nor any author of any information contained in this publication is rendering any professional services, and the Steel Deck Institute and/or any author of any information contained in this publication assumes no duty or responsibility with respect to any person making use of the information contained in this publication. In addition, neither the Steel Deck Institute, any of its Members or Associate Members nor the author of any information contained in this publication shall be liable for any claim, demand, injury, damage, loss, expense, cost or liability of any kind whatsoever which, directly or indirectly, in any way or manner arises out of or is connected with the use of the information contained in this publication, whether or not such claim, demand, loss, expense, or liability results directly or indirectly from any action or omission of the Steel Deck Institute, any of its Members or Associate Members or the author of any material contained in this publication. Any party using the information contained in this publication assumes all risk and liability arising from such use.

Since hazards may be associated with the handling, installation, or use of steel products, prudent construction practices should always be followed. The Steel Deck Institute recommends that parties involved in the handling, installation or use of steel construction products review all applicable manufacturers' material safety data sheets, applicable rules and regulations of the Occupational Safety and Health Administration and other government agencies having jurisdiction over such handling, installation or use, and other relevant construction practice publications.

First Printing, December 2024

Copyright © 2024 By Steel Deck Institute  
P.O. Box 70  
Florence, South Carolina 29503

*This Standard or any part thereof must not be reproduced in any form without the written permission of the Steel Deck Institute*

## PREFACE

(This Preface is not part of the ANSI/SDI AISI S908-2017 (R2024), *Test Standard for Determining the Flexural Strength Reduction Factor of Purlins Supporting a Standing Seam Roof System*, but is included for informational purposes only.)

This Standard is a reaffirmation of ANSI/ AISI S908-2017.

This Standard has been developed as a consensus document for the design of cold-formed steel members and structures. The intention is to provide criteria for routine use and not to provide specific criteria for infrequently encountered problems, which occur in the full range of structural design. The Symbols and Appendices to this Standard are an integral part of the Standard. A non-mandatory Commentary has been prepared to provide background for the Standard provisions and the user is encouraged to consult it. Additionally, non-mandatory User Notes may be interspersed throughout the Standard to provide concise and practical guidance in the application of the provisions. The user is cautioned that professional judgment must be exercised when data or recommendations in the Standard are applied, as described more fully in the disclaimer notice preceding this Preface.



AISI S908-17



# **AISI** STANDARD

## **Test Standard for Determining the Flexural Strength Reduction Factor of Purlins Supporting a Standing Seam Roof System**

2017 Edition

Approved by  
the AISI Committee on Specifications for the Design of  
Cold-Formed Steel Structural Members

The material contained herein has been developed by the American Iron and Steel Institute (AISI) Committee on Specifications for the Design of Cold-Formed Steel Structural Members. The organization and the Committee have made a diligent effort to present accurate, reliable, and useful information on testing of cold-formed steel members, components or structures. The Committee acknowledges and is grateful for the contributions of the numerous researchers, engineers, and others who have contributed to the body of knowledge on the subject. With anticipated improvements in understanding of the behavior of cold-formed steel and the continuing development of new technology, this material will become dated. It is anticipated that future editions of this test procedure will update this material as new information becomes available, but this cannot be guaranteed.

The materials set forth herein are for general information only. They are not a substitute for competent professional advice. Application of this information to a specific project should be reviewed by a registered professional engineer. Indeed, in most jurisdictions, such review is required by law. Anyone making use of the information set forth herein does so at their own risk and assumes any and all resulting liability arising therefrom.

1st Printing – April 2018  
2nd Printing – January 2022

Produced by American Iron and Steel Institute  
Copyright American Iron and Steel Institute 2018

## PREFACE

The American Iron and Steel Institute Committee on Specifications developed this Standard to obtain the reduction factor for use in determining the nominal flexural strength [resistance] of a purlin supporting a *standing seam roof system*.

The Committee acknowledges and is grateful for the contribution of the numerous engineers, researchers, producers and others who have contributed to the body of knowledge on this subject.

Commentary is non-mandatory and copyrightable portion of this Standard.

In the second printing, the definitions of “fixed clip” and “sliding clip” were deleted. A sentence was added to the commentary as the second to the last paragraph.

**This Page is Intentionally Left Blank.**

**AISI Committee on Specifications for the Design  
of Cold-Formed Steel Structural Members**

R. B. Haws, <i>Chairman</i>	Nucor Buildings Group
S. R. Fox, <i>Vice-Chairman</i>	Canadian Sheet Steel Building Institute
H. H. Chen, <i>Secretary</i>	American Iron and Steel Institute
D. Allen	Super Stud Building Products
P. Bodwell	Verco Decking, Inc.
R. L. Brockenbrough	R. L. Brockenbrough and Associates
J. Buckholt	Computerized Structural Design
J. K. Crews	Unarco Material Handling, Inc.
L. R. Daudet	Simpson Strong-Tie
R. S. Douglas	National Council of Structural Engineers Associations
W. S. Easterling	Virginia Polytechnic Institute and State University
D. Fulton	Triangle Fastener Corporation
R. S. Glauz	RSG Software, Inc.
P. S. Green	Bechtel Power Corporation
W. B. Hall	University of Illinois
G. J. Hancock	University of Sydney
A. J. Harrold	BlueScope Buildings North America
L. Kruth	American Institute of Steel Construction
R. L. Madsen	Supreme Steel Framing System Association
J. A. Mattingly	Consultant
W. McRoy	ICC Evaluation Service, Inc.
C. Moen	NBM Technologies, Inc.
J. R. U. Mujagic	Structural Engineering Consultant
N. A. Rahman	The Steel Network, Inc.
G. Ralph	ClarkDietrich Building Systems
V. E. Sagan	Metal Building Manufacturers Association
T. Samiappan	OMG, Inc.
A. Sarawit	Simpson Gumpetz & Heger
B. W. Schafer	Johns Hopkins University
K. Schroeder	Devco Engineering Inc.
T. Sputo	Steel Deck Institute
R. Ziemian	Structural Stability Research Council



### Subcommittee 6 – Test-Based Design

L. R. Daudet, <i>Chairman</i>	Simpson Strong-Tie
H. H. Chen, <i>Secretary</i>	American Iron and Steel Institute
R. S. Douglas	National Council of Structural Engineers Associations
D. Fox	TOTAL JOIST By ISPAN Systems
S. R. Fox	Canadian Sheet Steel Building Institute
W. Gould	ICC Evaluation Service, Inc.
P. S. Green	Bechtel Power Corporation
W. B. Hall	University of Illinois
R. B. Haws	Nucor Buildings Group
R. L. Madsen	Supreme Steel Framing System Association
J. R. Martin	Verco Decking, Inc.
C. Moen	NBM Technologies, Inc.
J.R.U. Mujagic	Structural Engineering Consultant
T. M. Murray	Consultant
K. Peterman	University of Massachusetts Amherst
N. A. Rahman	The Steel Network, Inc.
G. Ralph	ClarkDietrich Building Systems
V. E. Sagan	Metal Building Manufacturers Association
T. Samiappan	OMG, Inc.
B. W. Schafer	Johns Hopkins University
M. Schmeida	Gypsum Association
R. Schuster	Consultant
F. Sesma	California Expanded Metal Products
M. Speicher	NIST Engineering Laboratory
T. Sputo	Steel Deck Institute
C. Yu	University of North Texas

**AISI S908-17**  
**TEST STANDARD FOR DETERMINING THE**  
**FLEXURAL STRENGTH REDUCTION FACTOR OF**  
**PURLINS SUPPORTING A STANDING SEAM ROOF SYSTEM**

**1. Scope**

**1.1** The purpose of this test Standard is to provide a method to obtain the reduction factor for use in determining the nominal flexural strength [resistance] of a purlin supporting a standing seam roof system.

**1.2** The test method, herein also referred as “Base Test Method,” applies to an assembly consisting of the standing seam panel, purlin, and attachment devices used in the system being tested. The test specimen boundary conditions, described in Section 8.6, apply only to standing seam roof systems for which the roof deck is positively anchored to the supporting structural system at one or more purlin or eave member lines.

**1.3** The Base Test Method is used to evaluate the nominal flexural strength [resistance] of C- and Z-sections of multi-span, multiple purlin line, standing seam systems, with or without discrete intermediate braces.

**1.4** The Base Test Method is applicable to both “rib” or “pan” type standing seam roof panels.

**1.5** The Base Test Method is conducted using standing seam roof panels, clips, fasteners, *insulation*, *thermal blocks*, discrete braces, and purlins as used in the actual standing seam roof system except as noted in Section 1.6.

**1.6** Tests conducted with *insulation* are applicable to identical systems with thinner or no *insulation*.

**2. Referenced Documents**

The following documents or portions thereof are referenced within this Standard and shall be considered as part of the requirements of this document:

- a. American Iron and Steel Institute (AISI), Washington, DC:  
*S100-16, North American Specification for the Design of Cold-Formed Steel Structural Members*
- b. ASTM International (ASTM), West Conshohocken, PA:  
*A370-16, Standard Test Methods and Definitions for Mechanical Testing of Steel Products*  
*E6-15, Standard Terminology Relating to Methods of Mechanical Testing*  
*IEEE/ASTM SI10-10, American National Standard for Metric Practice*

**3. Terminology**

Where the following terms appear in this Standard, they shall have the meaning as defined herein. Terms not defined in Section 3 of this Standard, AISI S100, ASTM E6, or IEEE/ASTM-SI10 shall have the ordinary accepted meaning for the context for which they are intended.

*Failure.* A stage at which the specimen will accept no further loading.

*Insulation.* Glass fiber blanket or rigid board.

*Lateral.* A direction normal to the span of the purlins in the plane of the roof sheets.

*Thermal Block.* Strips of rigid *insulation* located directly over the purlin between clips.

*Negative Moment.* A moment which causes tension in the purlin flange attached to the clips and standing seam panels.

*Pan-Type Standing Seam Roof.* A U-shaped panel which has vertical sides.

*Positive Moment.* A moment which causes compression in the purlin flange attached to the clips and standing seam panels.

*Rib-Type Standing Seam Roof.* A panel that has ribs with sloping sides and forms a trapezoidal-shaped void at the sidelap.

*Standing Seam Roof System.* A roof system in which the sidelaps between the roof panels are arranged in a vertical position above the roof line. The roof panel system is secured to the purlins by means of concealed hold-down clips that are attached to the purlins with mechanical fasteners.

*Yield Stress.* Generic term to denote either yield point or yield strength, as appropriate for the material.

#### 4. Symbols:

b	= Flange width of the purlin
d	= Depth of the purlin
B	= Purlin spacing
$F_y$	= Design <i>yield stress</i>
$F_{yt}$	= Measured <i>yield stress</i> of tested purlin
$I_x$	= Moment of inertia of full unreduced section about x-axis
$I_{xy}$	= Product of inertia of flange about major axis
L	= Span of the purlins tested, center to center of the supports
$M_n$	= Nominal flexural strength [resistance] of a fully constrained beam, $S_e F_y$
$\bar{M}_{nt_{min}}$	= Average flexural strength [resistance] of the thinnest sections tested
$\bar{M}_{nt_{max}}$	= Average flexural strength [resistance] of the thickest sections tested
$M_{nt}$	= Flexural strength [resistance] of a tested purlin, $S_{et} F_{yt}$
$M_{ts}$	= <i>Failure</i> moment for the single span purlins tested, $w_{ts} L^2 / 8$
$p_d$	= Weight of the specimen (force/area)
$p_{ts}$	= <i>Failure</i> load (force/area) of the single span system tested
$P_L$	= <i>Lateral</i> anchorage force in accordance with Section I6.3.1 of AISI S100
$R_t$	= Modification factor from test, $M_{ts} / M_{nt}$
R	= Reduction factor computed for nominal purlin properties
$R_{t_{min}}$	= Mean minus one standard deviation of the modification factors of the three thinnest purlins tested
$R_{t_{max}}$	= Mean minus one standard deviation of the modification factors of the three thickest purlins tested
s	= Tributary width of the purlins tested
$S_e$	= Section modulus of the effective section
$S_{et}$	= Section modulus of the effective section of the tested member using measured

- dimensions and the measured *yield stress*
- t = Purlin thickness
- w<sub>ts</sub> = *Failure* load (force/length) of the single span purlins tested

## 5. Units of Symbols and Terms

Any compatible system of measurement units is permitted to be used in this Standard, except where explicitly stated otherwise. The unit systems considered in this Standard shall include U.S. customary units (force in kips and length in inches) and SI units (force in Newtons and length in millimeters) in accordance with IEEE/ASTM-SI10.

## 6. Measurement Precision

**6.1** Differential air pressure shall be recorded to a precision of  $\pm 0.1$  psf (5 Pa).

**User Note:**

The capacity (range) of the pressure-measuring device should be appropriate to the expected maximum tested value. The use of a measuring device with a calibrated capacity greatly exceeding the anticipated value is inappropriate. A target ratio of the measuring device capacity to maximum tested pressure of no greater than three is recommended.

**6.2** Deflections shall be recorded to a precision of 0.01 in. (0.25 mm).

## 7. Test Fixture

**7.1** The testing apparatus shall consist of a test chamber capable of supporting a positive or negative internal pressure differential. A rectangular frame shall be constructed of any material with the strength and rigidity to provide the desired pressure differential without collapse. See Figure 1 for a typical test chamber. Other chamber orientations are permitted.

**7.2** The length of the chamber shall be determined by the maximum length of the purlins as required by Section 9.2. The width of the chamber shall be determined by the maximum panel length as required by Section 8.9. Allowance shall be made in the interior chamber dimensions to accommodate structural supports for the purlins and sufficient clearance on all sides to prevent interference of the chamber wall with the test specimen as it deflects.

**7.3** The height of the chamber shall permit assembly of the specimen and ensure adequate clearance at the maximum deflection of the specimen.

**7.4** The chamber shall be sealed in a manner to prevent air leakage. All load-carrying elements of the specimen or its supports shall transfer the load to the frame support. The specimen, including intermediate brace, shall not be attached to the chamber in any manner that would impede the deflection of the specimen.

**7.5** The test chamber shall be sealed against air leakage by applying 6-mil (0.15-mm) maximum thickness polyethylene sheets, large enough to accommodate the system configuration and deflections. The polyethylene sheets shall be located on the high-pressure side of the panel with sufficient folds so as not to inhibit the spread of panel ribs under load. Edges of the polyethylene sheets shall be sealed against air leakage with tape or other suitable methods. Polyethylene sheets around the perimeter of the specimen shall be draped so as not to impede deflection or deformation of the specimen.

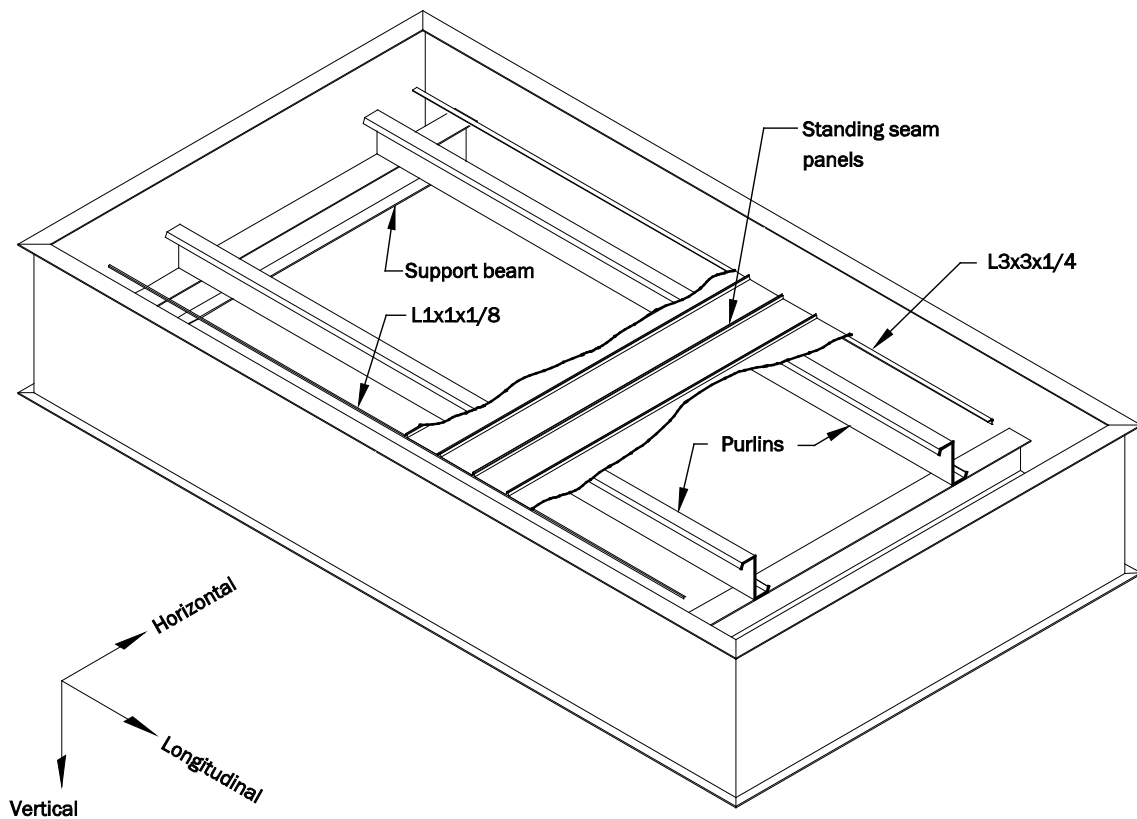

Deflection directions

**Figure 1 – Test Chamber**

**7.6** When a specimen smaller than the test chamber is tested, other panels and structures shall be installed to complete the coverage of the chamber opening. No attachment shall be made between the test specimen and this supplemental coverage.

**7.7** An air pump shall be used to create the pressure differential in the chamber. The pump shall be of enough capacity to reach the required test values by the applicable specifications.

**7.8** The type of air pump being used shall determine the method of control. This control shall be able to regulate the pressure differential in the chamber to  $\pm 1$  psf (0.05 kPa). This shall be accomplished by: (a) a variable speed motor on the pump, (b) valving on the pump, or (c) variable-size orifices on the chamber. It is permitted to use multiple pumps where

very large chambers are being used. One pump connection to the chamber shall be satisfactory.

**7.9** A minimum of two pressure differential measuring devices shall be monitored throughout the duration of the test.

**8. Test Specimen**

**8.1** Test purlins shall be supported at each end by a steel beam. The beams shall be simply supported, and one of the frame end beams shall be free to translate laterally to relieve any longitudinal catenary forces in the specimen. Purlins shall be connected to the supporting beams as recommended in the field erection drawings. Figure 1 shows the directional axes that are referred to in this test procedure.

**8.2** Panel-supporting clips, fasteners, and panels shall be installed as recommended in the field erection drawings.

**8.3** Means of providing restraint of purlins at the support shall be as required for use in actual field application, and shall be installed as recommended on the field erection drawings.

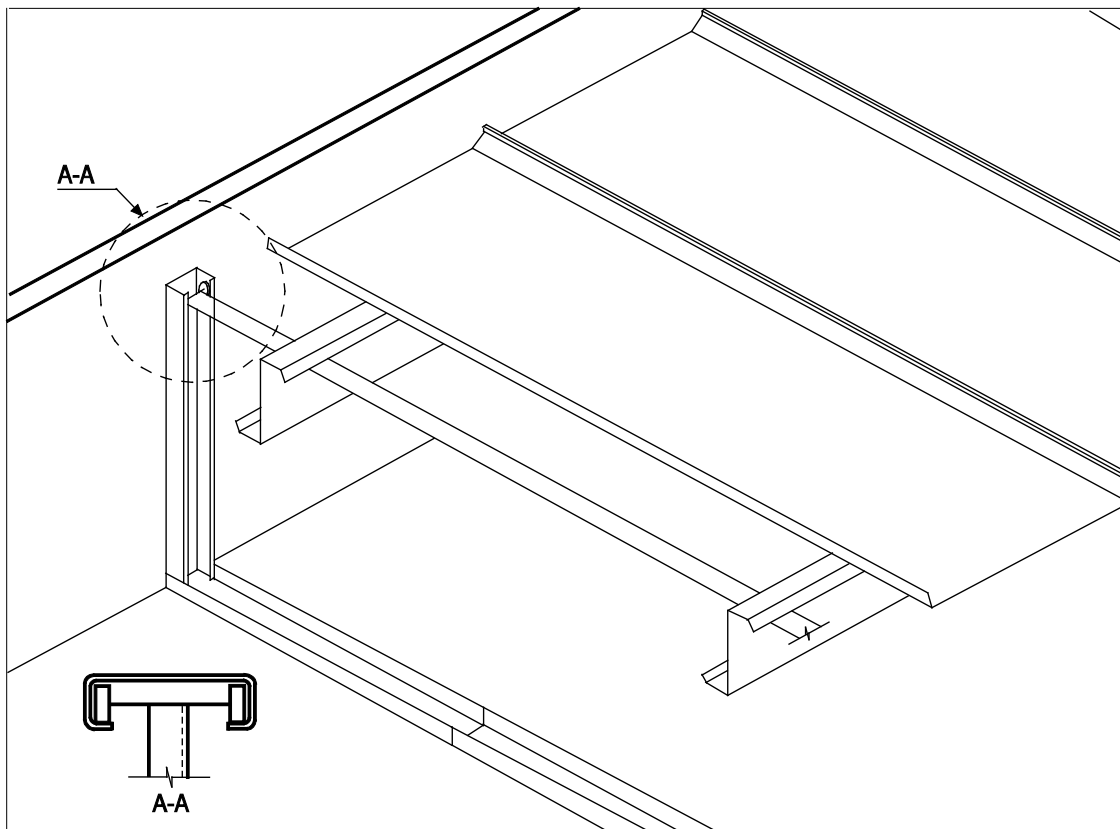

**Figure 2 - Example of Lateral Restraint Test Device**

**8.4** The purlins shall be arranged either with their flanges facing in the same direction or with their flanges opposed. If the test is performed with the purlin flanges opposed, they shall be field-installed with their flanges opposed.

**8.5** For tests including intermediate discrete point braces, the braces used in the test shall be installed in such a manner so as not to impede the vertical deflection of the specimen.

**User Note:**

Figure 2 shows one means of satisfying this requirement.

**8.6** A 1 in.  $\times$  1 in. (25 mm  $\times$  25 mm) continuous angle with a maximum thickness of 1/8 in. (3 mm) or a member of compatible stiffness shall be attached to the underside at each end of the panels to prevent separation of the panels at the ends of the seam. Fasteners shall be placed on both sides of each major rib. If the specimen is arranged with the purlin flanges facing in the same direction, a 3 in.  $\times$  3 in. (76 mm  $\times$  76 mm) continuous angle with a maximum thickness of 1/4 in. (6 mm) or a member of compatible stiffness is permitted to be substituted for the 1 in.  $\times$  1 in. (25 mm  $\times$  25 mm) angle at the end of the panel, corresponding to the eave of the building using the standard panel to eave fastening system (See Figure 1).

**8.7** All transverse panel ends shall be left free to displace vertically under load. When the 3 in.  $\times$  3 in. (76 mm  $\times$  76 mm) eave angle is used and the purlin flanges face in the same direction, the eave angle is permitted to be restrained against horizontal deflection at its ends as shown in Figure 1, providing vertical deflection is left unrestrained.

**8.8** Panel joints shall not be taped, and no tape shall be used to restrict panel movement.

**8.9** Panel length to be used in the test shall be, as a minimum, that length which provides full engagement of the panel to purlin clip and attachment of the 1 in.  $\times$  1 in. (25 mm  $\times$  25 mm) angle at the panel ends; but a length not greater than that required to achieve zero slope of the panel at the purlin support.

**8.10** The spacing of purlins being tested shall not exceed the spacing practically used with the roof system. Results from this test are permitted to be used in designing purlins of the same profile that are spaced closer together than the spacing used in the tests.

## 9. Test Procedure

**9.1** A test series shall be conducted for each purlin profile, specified steel grade, and each panel system. Any variation in the characteristics or dimensions of panel or clip shall constitute a change in panel system. The thickness of *insulation* used in the test shall be applicable to identical systems with thinner or no *insulation*. Any change in purlin shape or dimension other than thickness shall constitute a change in profile. However, the lip dimension is permitted to vary with section thickness consistent with the member design and not constitute a change in profile.

**9.2** No fewer than six tests shall be run for each combination of purlin profile and panel system. Three tests shall be conducted with the thinnest purlin of the profile, and three tests shall be conducted with the thickest purlin of the profile. All tests shall be conducted using the same purlin span which is the same or greater than the span used in actual field conditions.

**9.3** If an inventory consists of different clip types, a specific purlin depth and profile but with different flange widths, and identical panel profiles except for thickness, a rational procedure is permitted to be used to reduce the number of required tests.

**9.4** The mechanical properties shall be determined in accordance with ASTM A370 using coupons taken from the web area of the failed purlin. Coupons shall not be taken from areas where cold-working stresses could affect the results.

**9.5** For gravity loading, a pressure differential load shall be applied to the system to produce a *positive moment* in the system. For uplift loading, a pressure differential load shall be applied to the system to produce a *negative moment* in the system.

**9.6** An initial load equal to 5 psf (0.25 kPa) differential pressure in the direction of the test load shall be applied and removed to set the zero readings before actual system loading begins.

**9.7** The system shall be loaded to *failure* and the mode of *failure* noted. The pressure differential at which the system fails shall be recorded as the *failure* load of the specimen. When the test must be stopped due to a flexural *failure* of the panel or web crippling of the purlin, it is permitted to exclude the test from the test program.

**9.8** Vertical deflection measurements shall be taken at the mid-span of both purlins. The deck deflection in the horizontal direction shall be measured at the seam joint nearest the center of the test specimen.

**9.9** Deflections and pressures shall be recorded at pressure intervals equal to a maximum of 20 percent of the anticipated *failure* load.

**10. Data Evaluation**

**10.1** The single span *failure* load shall be obtained from the Base Test Method where a uniform load is applied until *failure* occurs. The computation of the *failure* load,  $w_{ts}$ , shall be dependent on the purlin orientation for Z-purlins and on the nature of the load as follows:

1. For Z-purlins tested for gravity loading, with flanges facing the same direction and with the top flanges of the purlins not restrained by anchorage to a point external to the panel/purlin system, the *failure* load shall be calculated as follows:

$$w_{ts} = (p_{ts} + p_d)s + 2P_L \left( \frac{d}{B} \right) \tag{1}$$

where

$$P_L = 0.5 \left( \frac{C2}{1000} \frac{I_{xy}L}{I_x d} + C3 \frac{0.25bt}{d^2} \right) (p_{ts} + p_d)s \tag{2}$$

	C2	C3
Standing Seam	8.3	28

2. For Z-purlins tested for gravity loading with flanges opposed and for C-sections tested for gravity loading, the *failure* load shall be determined as follows:

$$w_{ts} = (p_{ts} + p_d)s \tag{3}$$

3. For Z-purlins or C-sections tested for uplift loading, the *failure* load shall be determined as follows:

$$w_{ts} = (p_{ts} - p_d)s \tag{4}$$

The expression  $2P_L(d/B)$  in Equation (1) takes into account the effect of the overturning moment on the system due to the anchorage forces, as defined in Section I6.4.1 of AISI S100, applied at the top flange of the purlin by the panel and resisted at the bottom flange of the purlin at the support. The expression  $2P_L(d/B)$  shall be applied only to Z-sections under gravity loading when the purlin flanges are facing in the same direction,



but shall not be included in those systems where discrete point braces are used when the braces are restrained from *lateral* movement. The expression  $2P_L(d/B)$  shall not be applied unless the downhill purlin is the first to fail.

**10.2** From the single span *failure* load,  $w_{ts}$ , the maximum single span *failure* moment,  $M_{ts}$ , shall be calculated as follows:

$$M_{ts} = w_{ts} L^2 / 8 \quad (5)$$

**10.3** The single span Base Test Method moment shall be the maximum moment that the system can resist with the purlin size used in the test. The maximum allowable moment of a roof system purlin, simple span or continuous, shall be limited by the results of this test. The gravity load results shall apply for *positive moment* regions in the span and uplift load results shall apply for *negative moment* regions in the span.

**10.4** Using Section F3 of AISI S100, the flexural strength of each tested purlin,  $M_{nt}$ , of a fully constrained beam shall be calculated as follows:

$$M_{nt} = S_{et} F_{yt} \quad (6)$$

where  $S_{et}$  is the section modulus of the effective section calculated using the measured cross-sectional dimensions and measured *yield stress* and  $F_{yt}$  is the measured *yield stress* obtained in accordance with Section 9.4.

**10.5** The modification factor,  $R_t$ , shall be calculated for each purlin tested as:

$$R_t = M_{ts} / M_{nt} \quad (7)$$

**10.6** For purlins of the same profile, specified steel grade, and panel system as tested, the reduction factor shall be calculated as follows:

$$R = \left( \frac{R_{t_{\max}} - R_{t_{\min}}}{\overline{M}_{nt_{\max}} - \overline{M}_{nt_{\min}}} \right) (M_n - \overline{M}_{nt_{\min}}) + R_{t_{\min}} \leq 1.0 \quad (8)$$

where

$R_{t_{\min}}$  = Mean minus one standard deviation of the modification factors of the three thinnest purlins tested, calculated in accordance with Section 10.5. This value may be greater than 1.0

$R_{t_{\max}}$  = Mean minus one standard deviation of the modification factors of the three thickest purlins tested, calculated in accordance with Section 10.5. This value may be greater than 1.0

$M_n$  = Nominal flexural strength [resistance] of section for which R is being evaluated ( $S_e F_y$ )

$\overline{M}_{nt_{\min}}$  = Average flexural strength [resistance] of the thinnest section tested, calculated in accordance with Section 10.4

$\overline{M}_{nt_{\max}}$  = Average flexural strength [resistance] of the thickest section tested, calculated in accordance with Section 10.4

**10.7** If the test is performed with the purlins opposed or with an eave member at one or more edges, the diaphragm strength and stiffness of the panel system shall be tested unless the purlins are also opposed in actual field usage. The anchorage forces for the system braced in the manner tested shall be calculated in accordance with Section I6.4.1 of AISI S100. The diaphragm strength of the panel system shall be equal to or greater than the

calculated brace force at the *failure* load of the purlin. The stiffness of the diaphragm shall be such that the deflection of the diaphragm is equal to or less than the purlin span divided by 360 when subjected to the calculated brace force at the *failure* load of the purlin.

## **11. Test Report**

**11.1** Documentation - The report shall include the name of the individual who performed the test and a brief description of the system being tested.

**11.2** The documentation shall include test details with a drawing showing the test fixture and indicating the components and their locations. A written description of the test setup detailing the basic concept, loadings, measurements, and assembly shall be included.

**11.3** The report shall include a drawing showing the actual geometry of all specimens including mechanical specifications and test results defining the actual material properties - material thickness, *yield stress*, tensile strength, and percent elongation.

**11.4** The report shall include the test designation, loading increments, displacements, mode of *failure*, *failure* load, and specimen included for each test.

**11.5** The report shall include a description summarizing the test program results that includes specimen type, span, *failure* moments for the test series, and the supporting calculations.

**This Page is Intentionally Left Blank.**

**AISI S908-7-C**  
**COMMENTARY ON TEST STANDARD FOR DETERMINING THE FLEXURAL STRENGTH**  
**REDUCTION FACTOR OF PURLINS SUPPORTING**  
**A STANDING SEAM ROOF SYSTEM**

This test Standard provides the requirements for evaluating the resisting moment for cold-formed C- and Z-sections used with *standing seam roof systems*. The resisting moment is the multiplication of a reduction factor and the moment resistance of the corresponding member under the fully braced condition. The reduction factor reflects the ability of a particular *standing seam roof system* to provide *lateral* and rotational support to the purlins to which it is attached. This applies to discrete *lateral* and torsional bracing when the sheeted flange of the purlin is the compression flange, as in gravity loading cases, and when the unsheeted flange is the compression flange, as in wind uplift cases.

Due to the many different types and construction of *standing seam roof systems* and their attachments, it is not practical to develop a generic method to predict the interaction of a particular *standing seam roof system* and supporting structure. Therefore, the amount of resisting moment which the supporting purlins can achieve can vary from the fully braced condition to the unbraced condition for a given system.

The test method, herein referred to as the “Base Test Method,” is the result of extensive testing of various combinations of purlins, standing seam panels, and fastening devices. The tests were conducted over several years, benefiting from the experience provided by technical and industry experts. This procedure utilizes the results obtained from single span tests to predict the strength of multi-span conditions. The validity of this test method has been established by a research program at Virginia Polytechnic Institute and State University and documented in References (Brooks and Murray, 1990a and 1990b; Rayburn and Murray, 1990; Anderson and Murray, 1991; Pugh and Murray, 1991; and Murray, 1997). Helpful information regarding the Base Test Method was also included in the CCFSS Technical Bulletin Vol. 12 (2003).

In Standard Section 9.3, a rational procedure is permitted to be used to reduce the number of required tests. Such a rational procedure has been provided in Reference (Trout and Murray, 2000).

The rate of increase of pressure should be regulated so that the failure load can be determined accurately.

Due to anchorage design revisions in the 2007 edition of AISI S100 (AISI, 2007), Equation (2) in S908-13 was revised accordingly. Equation (2) is the simply supported case of *Specification* Equation I6.4.1-2 with  $\theta = 0$ .

**References**

- American Iron and Steel Institute (2007), *North American Specification for the Design of Cold-Formed Steel Structural Members*, 2007.
- AISI Task Committee on Base Test and Anchorage Questions, “Frequently Asked Questions Concerning the AISI Base Test Method and the Uses of the AISI Anchorage Equations,” CCFSS Technical Bulletin, Vol. 12, No. 1, University of Missouri – Rolla, Rolla, Missouri, 2003.

Brooks, S. and T. Murray (1990a), "Evaluation of the Base Test Method for Predicting the Flexural Strength of Standing Seam Roof Systems Under Gravity Loading," MBMA Project 403, VPI Report No. CE/VPI-ST89/07, Metal Building Manufacturers Association, 1300 Sumner Ave., Cleveland, Ohio 44115, July 1989, Revised November 1990.

Brooks, S. and T.M. Murray (1990b), "A Method for Determining the Strength of Z- and C-Purlin Supported Standing Seam Roof Systems, Recent Research and Developments in Cold-Formed Steel Design and Construction," *Proceedings of the Tenth International Specialty Conference on Cold-Formed Steel Structures*, St. Louis, MO, October 23-24, 1990, pp. 421-440.

Rayburn, L. and T.M. Murray (1990), "Base Test Method for Gravity Loaded Standing Seam Roof Systems," MBMA Project 502, VPI Report No. CE/VPI-ST90/07, Metal Building Manufacturers Association, 1300 Sumner Ave., Cleveland, Ohio, 44115, December 1990.

Anderson, B. and T.M. Murray (1991), "Base Test Method for Standing Seam Roof Systems Subject to Uplift Loading—Phase I," MBMA Project 501, VPI Report No. CE/VPI-ST90/06, Metal Building Manufacturers Association, 1300 Sumner Ave., Cleveland, Ohio 44115, December 1990, Revised December 1991.

Pugh, A. and T.M. Murray (1991), "Base Test Method for Standing Seam Roof Systems Subject to Uplift Loading—Phase II," MBMA Project 602, VPI Report No. CE/VPI-ST91/17, Metal Building Manufacturers Association, 1300 Sumner Ave., Cleveland, Ohio 44115, December 1991.

Murray, T.M. (1997), "Base Test Method for Uplift Loading—Final Report," MBMA Projects 501, 602 and 702, VPI Report No. CE/VPI-ST-97/10, Metal Building Manufacturers Association, 1300 Sumner Ave., Cleveland, Ohio 44115, November 1997.

Trout, A.M. and T.M. Murray (2000), "Reduced Number of Base Tests," Research Report CE/VPI-ST00/17 submitted to Metal Building Manufacturers Association, 1300 Sumner Ave., Cleveland, Ohio, 44115, December 2000.



# Sci