



AMERICAN NATIONAL STANDARDS INSTITUTE/ STEEL DECK INSTITUTE

ANSI/SDI AISI S918-2017 (R2024)

**Test Standard for Determining the Fastener-Sheathing
Rotational Stiffness of Sheathed Cold-Formed Steel
Assemblies**



DISCLAIMER

The information presented in this publication has been prepared in accordance with recognized engineering principles but is for general information only. While it is believed to be accurate, this information should not be used or relied upon for any general or specific application without a review and verification of its accuracy and applicability by a Registered/Licensed Professional Engineer, Designer or Architect. Neither the Steel Deck Institute nor the author of any information contained in this publication makes any representation or warranty, expressed or implied, respecting any of the information contained in this publication, including, but not limited to, the accuracy, completeness, or suitability of such information for any particular purpose or use and the Steel Deck Institute and each such author expressly disclaims any and all warranties, expressed or implied, regarding the information contained in this publication. By making this information available, neither the Steel Deck Institute nor any author of any information contained in this publication is rendering any professional services, and the Steel Deck Institute and/or any author of any information contained in this publication assumes no duty or responsibility with respect to any person making use of the information contained in this publication. In addition, neither the Steel Deck Institute, any of its Members or Associate Members nor the author of any information contained in this publication shall be liable for any claim, demand, injury, damage, loss, expense, cost or liability of any kind whatsoever which, directly or indirectly, in any way or manner arises out of or is connected with the use of the information contained in this publication, whether or not such claim, demand, loss, expense, or liability results directly or indirectly from any action or omission of the Steel Deck Institute, any of its Members or Associate Members or the author of any material contained in this publication. Any party using the information contained in this publication assumes all risk and liability arising from such use.

Since hazards may be associated with the handling, installation, or use of steel products, prudent construction practices should always be followed. The Steel Deck Institute recommends that parties involved in the handling, installation or use of steel construction products review all applicable manufacturers' material safety data sheets, applicable rules and regulations of the Occupational Safety and Health Administration and other government agencies having jurisdiction over such handling, installation or use, and other relevant construction practice publications.

First Printing, December 2024

Copyright © 2024 By Steel Deck Institute
P.O. Box 70
Florence, South Carolina 29503

This Standard or any part thereof must not be reproduced in any form without the written permission of the Steel Deck Institute

PREFACE

(This Preface is not part of the ANSI/SDI AISI S918-2017 (R2024), *Test Standard for Determining the Fastener-Sheathing Rotational Stiffness of Sheathed Cold-Formed Steel Assemblies*, but is included for informational purposes only.)

This Standard is a reaffirmation of ANSI/ AISI S918-2017.

This Standard has been developed as a consensus document for the design of cold-formed steel members and structures. The intention is to provide criteria for routine use and not to provide specific criteria for infrequently encountered problems, which occur in the full range of structural design. The Symbols and Appendices to this Standard are an integral part of the Standard. A non-mandatory Commentary has been prepared to provide background for the Standard provisions and the user is encouraged to consult it. Additionally, non-mandatory User Notes may be interspersed throughout the Standard to provide concise and practical guidance in the application of the provisions. The user is cautioned that professional judgment must be exercised when data or recommendations in the Standard are applied, as described more fully in the disclaimer notice preceding this Preface.



AISI S918-17



AISI STANDARD

Test Standard for Determining the Fastener-Sheathing Rotational Stiffness of Sheathed Cold-Formed Steel Assemblies

2017 Edition

Approved by
the AISI Committee on Specifications for the Design of
Cold-Formed Steel Structural Members

DISCLAIMER

The material contained herein has been developed by the American Iron and Steel Institute (AISI) Committee on Specifications. The organization and the Committee have made a diligent effort to present accurate, reliable, and useful information on testing of cold-formed steel members, components or structures. The Committee acknowledges and is grateful for the contributions of the numerous researchers, engineers, and others who have contributed to the body of knowledge on the subject. With anticipated improvements in understanding of the behavior of cold-formed steel and the continuing development of new technology, this material will become dated. It is anticipated that future editions of this test procedure will update this material as new information becomes available, but this cannot be guaranteed.

The materials set forth herein are for general information only. They are not a substitute for competent professional advice. Application of this information to a specific project should be reviewed by a registered professional engineer. Indeed, in most jurisdictions, such review is required by law. Anyone making use of the information set forth herein does so at their own risk and assumes any and all resulting liability arising therefrom.

1st Printing – December 2016

Produced by American Iron and Steel Institute

Copyright American Iron and Steel Institute 2016

PREFACE

The American Iron and Steel Institute Committee on Specifications developed this Standard to determine the rotational restraint (k_{ϕ}) supplied by sheathing, fastened to cold-formed steel members.

The Committee acknowledges and is grateful for the contribution of the numerous engineers, researchers, producers and others who have contributed to the body of knowledge on this subject.

User Notes and Commentary are nonmandatory and copyrightable portions of this Standard.

This Page is Intentionally Left Blank.

**AISI Committee on Specifications for the Design
of Cold-Formed Steel Structural Members**

R. L. Brockenbrough, <i>Chairman</i>	R. L. Brockenbrough and Associates
R. B. Haws, <i>Vice-Chairman</i>	Nucor Buildings Group
H. H. Chen, <i>Secretary</i>	American Iron and Steel Institute
D. Allen	Super Stud Building Products
P. Bodwell	Verco Decking
J. Buckholt	Computerized Structural Design
C. J. Carter	American Institute of Steel Construction
J. K. Crews	Unarco Material Handling, Inc.
L. R. Daudet	Simpson Strong-Tie
S. Douglas	National Council of Structural Engineers Association
W. S. Easterling	Virginia Polytechnic Institute and State University
J. M. Fisher	Consultant
S. R. Fox	Canadian Sheet Steel Building Institute
D. Fulton	Triangle Fastener Corporation
R. S. Glauz	RSG Software, Inc.
P. S. Green	Bechtel Power Corporation
W. B. Hall	University of Illinois
G. J. Hancock	University of Sydney
A. J. Harrold	Butler Manufacturing Company
R. A. LaBoube	Wei-Wen Yu Center for Cold-Formed Steel Structures
R. L. Madsen	Supreme Steel Framing System Association
J. A. Mattingly	Consultant
W. McRoy	ICC Evaluation Service, LLC.
J. R. U. Mujagic	Consultant
N. A. Rahman	The Steel Network, Inc.
G. Ralph	ClarkDietrich Building Systems
V. E. Sagan	Metal Building Manufacturers Association
T. Samiappan	OMG, Inc.
A. Sarawit	Simpson Gumpetz & Heger
B. W. Schafer	The Johns Hopkins University
K. Schroeder	Devco Engineering Inc.
R. M. Schuster	Consultant
T. Sputo	Steel Deck Institute
R. Ziemian	Structural Stability Research Council

Subcommittee 6 – Test-Based Design

L. R. Daudet, <i>Chairman</i>	Simpson Strong-Tie
H. H. Chen, <i>Secretary</i>	American Iron and Steel Institute
J. DesLaurier	Certified Steel Stud Association
S. Douglas	National Council of Structural Engineers Association
D. Fox	TOTAL JOIST By ISPAN Systems
S. R. Fox	Canadian Sheet Steel Building Institute
B. Gerber	IAPMO Uniform Evaluation Service
W. Gould	ICC Evaluation Service, LLC.
P. S. Green	Bechtel Power Corporation
W. B. Hall	University of Illinois
J. R. Martin	Verco Decking, Inc.
C. Moen	NBM Technologies, Inc.
T. M. Murray	Consultant
R. V. Nunna	S. B. Barnes Associates
J. Nunnery	Consultant
N. A. Rahman	The Steel Network, Inc.
G. Ralph	ClarkDietrich Building Systems
V. Sagan	Metal Building Manufacturers Association
T. Samiappan	OMG, Inc.
B. W. Schafer	The Johns Hopkins University
M. Schmeida	Gypsum Association
R. M. Schuster	Consultant
F. Sesma	California Expanded Metal Products
T. Sputo	Steel Deck Institute

AISI S918-17
TEST STANDARD FOR DETERMINING THE FASTENER-SHEATHING
ROTATIONAL STIFFNESS OF SHEATHED COLD-FORMED
STEEL ASSEMBLIES

1. Scope

This Standard shall apply for the determination of the rotational restraint (k_ϕ) supplied by sheathing, fastened to cold-formed steel members. This Standard consists of Sections 1 through 10 inclusive.

Commentary:

This test standard is conceptually related to AISI S901; however, the specifics of the test and instrumentation are modified for the use intended here. When a cold-formed steel member is connected to sheathing, the sheathing can provide beneficial rotational restraint of the member (stud, joist, etc.). One direct mechanism for developing such rotational restraint is a combination of bearing between the flange and sheathing, and pull-through resistance at a fastener location, as the member rotates. This mechanical combination may be idealized as a rotational restraint at the fastener location. This rotational restraint provides the primary bracing restraint against distortional buckling. See Schafer et al. (2010) for a complete discussion.

Reference:

Schafer, B. W., L. C. M. Vieira Jr., R. H. Sangree, and Y. Guan (2010), "Rotational Restraint and Distortional Buckling in Cold-Formed Steel Framing Systems," *Revista Sul-Americana de Engenharia Estrutural* (South American Journal of Structural Engineering), *Special Issue on Cold-Formed Steel Structures*, 7 (1) 71-90.

2. Referenced Documents

The following documents or portions thereof are referenced within this Standard and shall be considered as part of the requirements of this document.

- a. American Iron and Steel Institute (AISI), Washington, DC:
S100-16, *North American Specification for the Design of Cold-Formed Steel Structural Members*
S240-15, *North American Standard for Cold-Formed Steel Structural Framing*
- b. ASTM International (ASTM), West Conshohoken, PA:
A370-14, *Standard Test Methods and Definitions for Mechanical Testing of Steel Products*
ASTM E6-09be1, *Standard Terminology Relating to Methods of Mechanical Testing*
IEEE/ASTM SI10-10, *American National Standard for Metric Practice*

3. Terminology

Terms not defined in AISI S100 or AISI S240 shall have the ordinary accepted meaning for the context for which they are intended.

4. Symbols

s_f = Fastener spacing

- h_o = Out-to-out depth of member
 k_ϕ = Rotational stiffness of sheathing-fastener to cold-formed steel member
 \bar{k}_ϕ = Sheathing-fastener rotational stiffness per unit length
 $\bar{k}_{\phi c}$ = Fastener rotational stiffness per unit length
 $\bar{k}_{\phi w}$ = Sheathing rotational stiffness per unit length
 L = Length (height) of sheathing from fixed end to fastener location
 \bar{M} = Rotational moment caused by P per unit width, w
 P = Vertical force applied at a distance, h_o , from member-sheathing connection
 P_u = Maximum test load
 t = Thickness of cold-formed steel member
 t_w = Thickness of sheathing
 w = Width of the test specimen
 Δ_v = Vertical displacement at face of flange where load, P , is applied
 Δ_h = Horizontal displacement of sheathing at fastener location
 θ = Rotation of cold-formed steel member due to vertical displacement
 θ_c = Net rotation of cold-formed steel member
 θ_w = Rotation of cold-formed steel member due to horizontal displacement

5. Precision

5.1 Loads shall be recorded to a precision of 1 percent of the maximum load during application of test loads.

5.2 Deflections shall be recorded to a precision of 0.001 in. (0.025 mm).

6. Test Fixture

6.1 The test consists of a cantilevered piece of sheathing fastened to a horizontally oriented member (i.e., joist, stud, etc.). An example test setup is provided in Figure 1.

6.2 The actuator that supplies the force to the end of the member shall be free to translate.

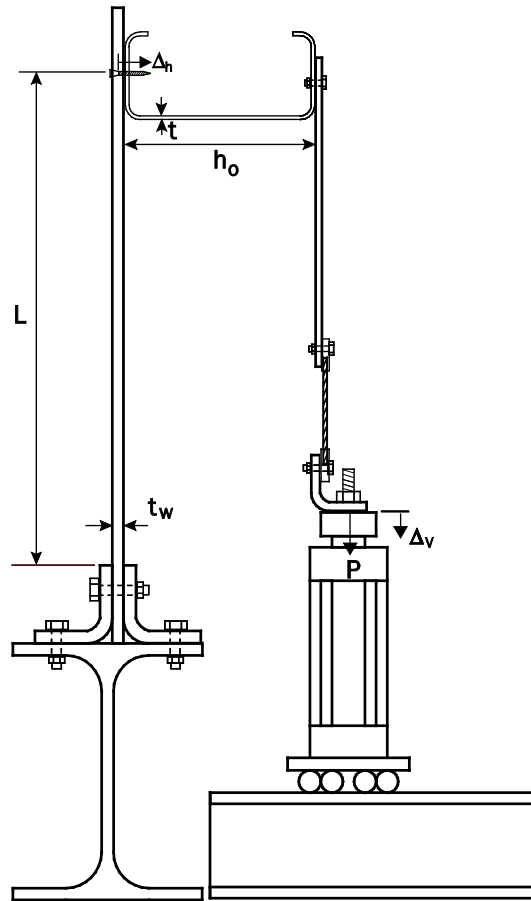

Figure 1 Side View of Cantilever Specimen

7. Test Specimen

The test specimen consists of the cold-formed steel member (joist, stud, etc.), fasteners, and sheathing.

7.1 The cold-formed steel member shall be representative of its intended end use. The member length shall be at least four times the fastener spacing.

7.2 The fasteners shall be representative of their intended end use. Sheathing screws are driven to the proper depth appropriate for the head style used: bugle, wafer and flat head screws shall be driven flush with the surface of the sheathing; pan head, round head, and hex washer head screws shall be driven with the bottom of the head flush with the sheathing. At least three fasteners shall be used per test. Fastener spacing shall match that in the intended end use.

7.3 The sheathing shall be representative of its intended end use. The sheathing width shall match the cold-formed steel member length. The sheathing length, L , shall be at least equal to $1/2$ the end use spacing between cold-formed steel members, but not less than 12 in. (305 mm).

8. Test Procedure

8.1 The test shall be conducted under pseudo-static monotonic load until a maximum (failure) load is reached. A loading rate of 0.2 in./min (5.1 mm/min) shall be applied unless it takes greater than 30 minutes to reach maximum load, in which case a faster load rate may be applied, but not faster than a rate that reaches maximum load in less than 5 minutes.

8.2 Displacement shall be measured in the test specimen. Actuator displacement (from the actuator internal LVDT) is permitted for use as the vertical displacement, Δ_v . If the rotational stiffness is to be separated into fastener and sheathing components (as utilized in AISI S240), then the horizontal displacement, Δ_h , must also be recorded.

9. Data Evaluation

9.1 The rotational stiffness of the fastener-sheathing system, k_ϕ , is determined at 40% of the ultimate strength (i.e., maximum load or P_u) of the specimen. Specifically, $P = 0.4P_u$ and Δ_v and Δ_h shall be determined at $0.4P_u$.

(a) Rotational stiffness if separation between fastener and sheathing is not needed:

$$k_\phi = (\bar{k}_\phi)(s_f) \quad (1)$$

$$\bar{k}_\phi = \bar{M} / \theta \quad (2)$$

$$\bar{M} = (P/w)h_o \quad (3)$$

$$\theta = \tan^{-1}(\Delta_v / h_o) \quad (4)$$

(b) Rotational stiffness if separation between fastener and sheathing is desired:

(i) Fastener rotational stiffness:

$$k_{\phi c} = (\bar{k}_{\phi c})(s_f) \quad (5)$$

$$\bar{k}_{\phi c} = \bar{M} / \theta_c = \bar{M} / (\theta - \theta_w) \quad (6)$$

$$\theta_w = 2\Delta_h / L \quad (7)$$

(ii) Sheathing rotational stiffness:

$$k_{\phi w} = \bar{k}_{\phi w} s_f \quad (8)$$

$$\bar{k}_{\phi w} = \bar{M} / \theta_w = \bar{M} / (2\Delta_h / L) \quad (9)$$

(iii) Total (sheathing and fastener) rotational stiffness:

$$k_\phi = \bar{k}_\phi s_f \quad (10)$$

$$\bar{k}_\phi = 1 / [(1/\bar{k}_{\phi c}) + (1/\bar{k}_{\phi w})] \quad (11)$$

Commentary:

Separation of the rotational stiffness into fastener and sheathing stiffness is conceptually summarized in Figure C-1. In existing testing (Schafer et al., 2010¹), the total rotational stiffness was found to be highly variable due principally to large variations in the sheathing properties; however, fastener rotational stiffness was found to be more repeatable. Both fastener and sheathing rotational stiffness are utilized in AISI framing standards, and may be replaced by the experimental values developed here.

¹Reference is provided in the Commentary in Section 1.

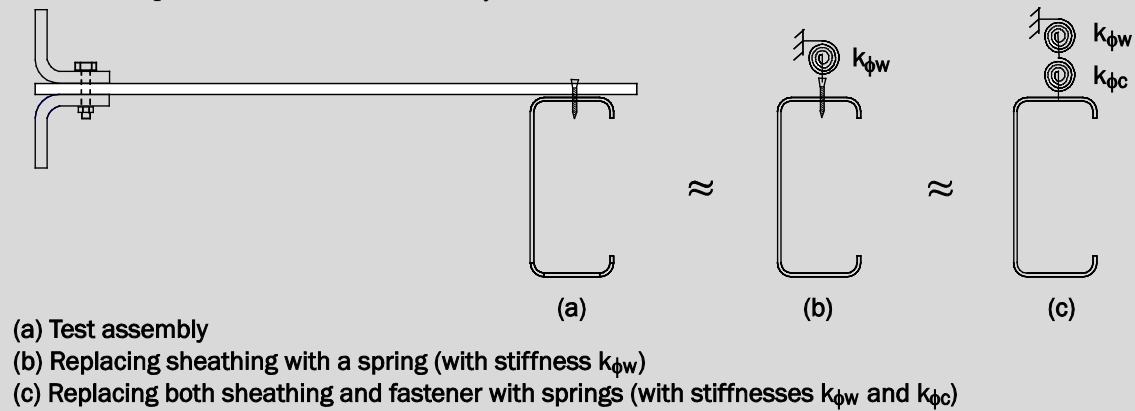

Figure C-1 Separation of Rotational Stiffness Into Fastener and Sheathing Components

9.2 The data evaluation shall be consistent with AISI S100, Section K2.1, that is: “Evaluation of the test results shall be made on the basis of the average value of test data resulting from tests of not fewer than three identical specimens, provided the deviation of any individual test result from the average value obtained from all tests does not exceed ± 15 percent. If such deviation from the average value exceeds 15 percent, more tests of the same kind shall be made until the deviation of any individual test result from the average value obtained from all tests does not exceed ± 15 percent, or until at least three additional tests have been made. No test result shall be eliminated unless a rationale for its exclusion can be given.” For this criteria, the evaluation of consistency shall be made on the rotational stiffness, k_{ϕ} , k_{ϕ_c} , and/or k_{ϕ_w} , and the maximum number of tests is permitted to be limited to 6.

10. Report

10.1 The test report shall include a description of the tested specimens, including a drawing detailing all pertinent dimensions.

10.2 The test report shall include the measured physical properties consistent with the limitations outlined in Section 7. Conditioning of the sheathing shall be documented.

Commentary:

The major item for documenting the sheathing conditioning is the relative humidity and moisture content, as it can potentially affect the performance of the sheathing material.

10.3 The test report shall include a detailed drawing of the test setup depicting locations and directions of load application, and locations of displacement instrumentation and their

point of reference. Additionally, photographs shall supplement the detailed drawings of the test setup.

10.4 The test report shall include load-versus-displacement values and curves, as plotted directly or as reprinted from data acquisition systems.

10.5 The stiffness determined at 40% of the maximum load (\bar{k}_ϕ) shall also be drawn on the moment-versus-rotation curves. Values of \bar{k}_ϕ shall be provided for all tested specimens.

10.6 The test report shall include individual and average maximum test load values observed (i.e., P_u); description of the nature, type and location of failure exhibited by each specimen tested; and a description of the general behavior of the test fixture during load application. Additionally, photographs shall supplement the description of the failure mode(s).

10.7 The test report shall include a description of the test method and loading procedure used, rate of loading, or rate of motion of the crosshead movement.



Solid