



AMERICAN NATIONAL STANDARDS INSTITUTE/ STEEL DECK INSTITUTE

ANSI/SDI AISI S922-2019 (R2024)

**Test Standard for Determining the Strength and Stiffness
of Bearing-Friction Interference Connector Assemblies in
Profiled Steel Panels**



DISCLAIMER

The information presented in this publication has been prepared in accordance with recognized engineering principles but is for general information only. While it is believed to be accurate, this information should not be used or relied upon for any general or specific application without a review and verification of its accuracy and applicability by a Registered/Licensed Professional Engineer, Designer or Architect. Neither the Steel Deck Institute nor the author of any information contained in this publication makes any representation or warranty, expressed or implied, respecting any of the information contained in this publication, including, but not limited to, the accuracy, completeness, or suitability of such information for any particular purpose or use and the Steel Deck Institute and each such author expressly disclaims any and all warranties, expressed or implied, regarding the information contained in this publication. By making this information available, neither the Steel Deck Institute nor any author of any information contained in this publication is rendering any professional services, and the Steel Deck Institute and/or any author of any information contained in this publication assumes no duty or responsibility with respect to any person making use of the information contained in this publication. In addition, neither the Steel Deck Institute, any of its Members or Associate Members nor the author of any information contained in this publication shall be liable for any claim, demand, injury, damage, loss, expense, cost or liability of any kind whatsoever which, directly or indirectly, in any way or manner arises out of or is connected with the use of the information contained in this publication, whether or not such claim, demand, loss, expense, or liability results directly or indirectly from any action or omission of the Steel Deck Institute, any of its Members or Associate Members or the author of any material contained in this publication. Any party using the information contained in this publication assumes all risk and liability arising from such use.

Since hazards may be associated with the handling, installation, or use of steel products, prudent construction practices should always be followed. The Steel Deck Institute recommends that parties involved in the handling, installation or use of steel construction products review all applicable manufacturers' material safety data sheets, applicable rules and regulations of the Occupational Safety and Health Administration and other government agencies having jurisdiction over such handling, installation or use, and other relevant construction practice publications.

First Printing, December 2024

Copyright © 2024 By Steel Deck Institute
P.O. Box 70
Florence, South Carolina 29503

*This Standard or any part thereof must not be reproduced in any form without the written permission of
the Steel Deck Institute*

PREFACE

(This Preface is not part of the ANSI/SDI AISI S922-2019 (R2024), *Test Standard for Determining the Strength and Stiffness of Bearing-Friction Interference Connector Assemblies in Profiled Steel Panels*, but is included for informational purposes only.)

This Standard is a reaffirmation of ANSI/ AISI S922-2019.

This Standard has been developed as a consensus document for the design of cold-formed steel members and structures. The intention is to provide criteria for routine use and not to provide specific criteria for infrequently encountered problems, which occur in the full range of structural design. The Symbols and Appendices to this Standard are an integral part of the Standard. A non-mandatory Commentary has been prepared to provide background for the Standard provisions and the user is encouraged to consult it. Additionally, non-mandatory User Notes may be interspersed throughout the Standard to provide concise and practical guidance in the application of the provisions. The user is cautioned that professional judgment must be exercised when data or recommendations in the Standard are applied, as described more fully in the disclaimer notice preceding this Preface.



AISI S922-19



AISI STANDARD

S 9 2 2 - 1 9

Test Standard for Determining the Strength and Stiffness of Bearing- Friction Interference Connector Assemblies in Profiled Steel Panels

2019 Edition

Approved by
the AISI Committee on Specifications for the Design of
Cold-Formed Steel Structural Members

DISCLAIMER

The material contained herein has been developed by the American Iron and Steel Institute Committee on Specifications for the Design of Cold-Formed Steel Structural Members. The organization and the Committee have made a diligent effort to present accurate, reliable, and useful information on testing of cold-formed steel members, components or structures. The Committee acknowledges and is grateful for the contributions of the numerous researchers, engineers, and others who have contributed to the body of knowledge on the subject. With anticipated improvements in understanding of the behavior of cold-formed steel and the continuing development of new technology, this material will become dated. It is anticipated that future editions of this test procedure will update this material as new information becomes available, but this cannot be guaranteed.

The materials set forth herein are for general information only. They are not a substitute for competent professional advice. Application of this information to a specific project should be reviewed by a registered professional engineer. Indeed, in most jurisdictions, such review is required by law. Anyone making use of the information set forth herein does so at their own risk and assumes any and all resulting liability arising therefrom.

1st Printing – January 2020

Copyright American Iron and Steel Institute 2020

This document is copyrighted by AISI. Any redistribution is prohibited.

PREFACE

The American Iron and Steel Institute Committee on Specifications developed this Standard to provide a test method for determining the strength and stiffness performance of bearing-friction interference connector assemblies installed in cold-formed profiled steel panels including *steel deck* and *steel deck-slabs*.

This Standard is intended for adoption and use when performance testing for determining the strength and stiffness of bearing-friction interference connector assemblies installed in profiled steel panels is required.

The Committee acknowledges and is grateful for the contributions of the numerous engineers, researchers, producers and others who have contributed to the body of knowledge on this subject.

This Page is Intentionally Left Blank.

**AISI Committee on Specifications for the Design
of Cold-Formed Steel Structural Members**

| | |
|---------------------------------|---|
| R. B. Haws, <i>Chairman</i> | Nucor Buildings Group |
| S. R. Fox, <i>Vice-Chairman</i> | Canadian Sheet Steel Building Institute |
| H. H. Chen, <i>Secretary</i> | American Iron and Steel Institute |
| D. Allen | Super Stud Building Products, Inc. |
| P. Bodwell | Verco Decking, Inc. |
| R. L. Brockenbrough | R. L. Brockenbrough and Associates |
| J. Buckholt | Computerized Structural Design |
| S. Call | Call Engineering |
| J. K. Crews | Unarco Material Handling, Inc. |
| R. S. Douglas | National Council of Structural Engineers Associations |
| W. S. Easterling | Iowa State University |
| P. Ford | Steel Framing Industry Association |
| R. S. Glauz | RSG Software, Inc. |
| P. S. Green | Bechtel Power Corporation |
| W. B. Hall | University of Illinois |
| G. J. Hancock | University of Sydney |
| A. J. Harrold | Consultant |
| L. Kruth | American Institute of Steel Construction |
| Z. Li | SUNY Polytechnic Institute |
| R. L. Madsen | Supreme Steel Framing System Association |
| J. A. Mattingly | Consultant |
| W. McRoy | ICC Evaluation Service, LLC |
| C. Melcher | Simpson Strong-Tie |
| C. Moen | NBM Technologies, Inc. |
| J. R. U. Mujagic | KATERRA |
| J. Pote | Steel Joist Institute |
| N. A. Rahman | FDR Engineers |
| G. Ralph | ClarkDietrich Building Systems |
| V. E. Sagan | Metal Building Manufacturers Association |
| T. Samiappan | Quick Tie Products |
| A. Sarawit | Simpson Gumpetz & Heger |
| B. W. Schafer | Johns Hopkins University |
| T. Sputo | Steel Deck Institute |
| S. Torabian | Cold-Formed Steel Research Consortium |
| C. Yu | University of North Texas |
| R. Zadeh | RAZ Tech, Inc. |
| R. Ziemian | Structural Stability Research Council |

AISI S922-19
TEST STANDARD FOR DETERMINING THE STRENGTH AND
STIFFNESS OF BEARING-FRICTION INTERFERENCE CONNECTOR
ASSEMBLIES IN PROFILED STEEL PANELS

1. Scope

This Standard shall apply for the determination of the strength and stiffness of bearing-friction interference connector assemblies in profiled steel panels. This Standard applies to connector assemblies with cold-formed profiled steel panels including *steel deck* and concrete-filled *steel deck-slabs* using an interference connector in a bearing connection, friction connection, or a combination thereof.

This Standard is composed of Sections 1 through 12 inclusive and Appendix A.

User Note:

The following figures depict common wedge-nut connections to re-entrant steel deck that are typical of the category of connections covered by this Standard. See Appendix A and Commentary Section C1 for additional common connection types and test configurations.

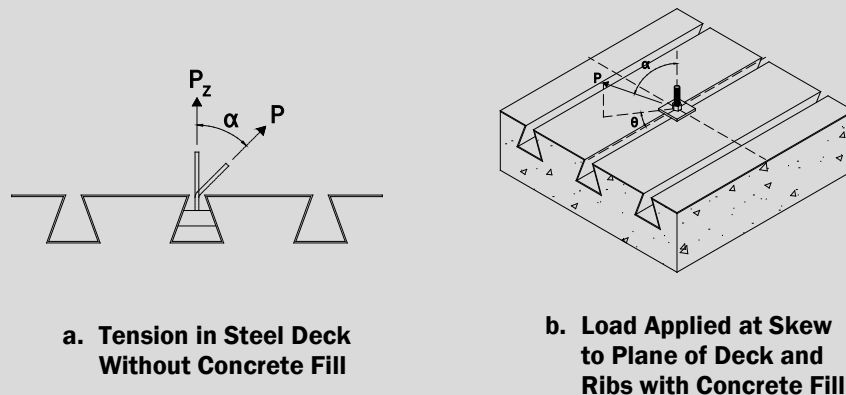

Figure 1-1

2. Referenced Documents

The following documents or portions thereof are referenced within this Standard and shall be considered as part of the requirements of this document.

- a. American Iron and Steel Institute (AISI), Washington, DC:
AISI S100-16, North American Specification for the Design of Cold-Formed Steel Structural Members, 2016 Edition
- b. American Concrete Institute (ACI), Farmington Hills, MI:
ACI 318-14, Building Code Requirements for Structural Concrete and Commentary
- c. ASTM International (ASTM), West Conshohocken, PA:
ASTM E4-16, Standard Practices for Force Verification of Testing Machines

A370-16, *Standard Test Methods and Definitions for Mechanical Testing of Steel Products*
 E6-15, *Standard Terminology Relating to Methods of Mechanical Testing*
 IEEE/ASTM SI10-10, *American National Standard for Use of the International System of Units (SI): The Modern Metric System*

- d. Applied Technology Council, Redwood City, CA:
 FEMA 461/June 2007, *Interim Testing Protocols for Determining the Seismic Performance Characteristics of Structural and Nonstructural Components*

3. Terminology

Where the following terms appear in this Standard, they shall have the meaning as defined herein. Terms not defined in Section 3 of this Standard, AISI S100, or ASTM E6 shall have the ordinary accepted meaning for the context for which they are intended.

Steel Deck. Profiled steel panels installed on support framing.

Steel Deck-Slab. *Steel deck* with structural or nonstructural concrete fill (topping).

Restrained Connection. A condition which provides transverse strength or stiffness to the ribs of the *steel deck* in addition to inherent transverse stiffness or strength of the *steel deck* to prevent the ribs from rolling open as manufactured. Connections in *steel deck-slabs* are always considered restrained.

Unrestrained Connection. A condition not meeting the *restrained connection* requirements.

4. Symbols

| | |
|-----------------|--|
| a, b | Location of the applied load relative to the span of the test specimen |
| D_d | Depth of <i>steel deck</i> |
| d_c | Depth of concrete fill above the <i>steel deck</i> |
| e_{\min} | Minimum eccentricity of the applied load in the plane of the <i>steel deck</i> |
| f'_c | Concrete compressive strength |
| L | Span length |
| P | Applied load |
| P_t | Adjusted applied load of a test for actual properties of the test to specified properties of the design |
| P_u | Ultimate applied load of a test |
| P_x, P_y, P_z | x, y, and z vector components of the applied load of the test relative to the plane of the <i>steel deck</i> |
| P_α | Applied load of a test for actual properties of the test to specified properties of the design at angle α |
| R | Reaction to applied load |
| R_x, R_y, R_z | x, y, and z vector components of reaction(s) relative to the plane of the <i>steel deck</i> |
| w_L | Length of the test specimen |

| | |
|----------|---|
| w_T | Transverse width of the test specimen |
| α | Angle of the applied load measured relative to a line normal to the plane of the <i>steel deck</i> |
| θ | Angle of the applied load measured relative to the parallel direction of the <i>steel deck</i> in the plane of the deck |

5. Units of Symbols and Terms

Any compatible system of measurement units is permitted to be used in this Standard, except where explicitly stated otherwise. The unit systems considered in this Standard shall include U.S. customary units (force in kips and length in inches) and SI units (force in Newtons and length in millimeters) in accordance with IEEE/ASTM SI10.

6. Precision

6.1 The rate of loading shall be controlled, constant loads shall be maintained, and the applied load shall be measured accurately within ± 1 percent of the full range of the measuring device.

User Note:

The capacity (range) of the load-measuring device should be appropriate to the expected maximum tested load. The use of a measuring device with a calibrated capacity greatly exceeding the anticipated load is not recommended. A target ratio of the load cell capacity to specimen strength of no greater than three is recommended.

The tests should be conducted on a testing machine that complies with the requirements of ASTM E4-16, *Standard Practices for Forces Verification of Testing Machines*.

6.2 Deflections shall be recorded to a precision of 0.001 in. (0.025 mm).

7. Test Fixture

7.1 Test fixtures shall be rigid enough to apply the loads in the intended orientation throughout the test without creating unintended eccentricities. When the test is for tension or compression loads, the test fixture shall not induce shear to the connection under the applied load. When the test is for shear loading, the test fixtures shall not induce tension or compression to the connection under the applied load. When the test is for combined shear and tension, that test fixture shall apply the load at the specified ratio of shear and tension under the applied load.

7.2 One of the following test fixtures shall be used for monotonic testing:

- Hydraulic or screw-operated testing machine operating at a constant rate of displacement or a constant rate of loading with a calibrated force and deflection-measuring devices,
- Hydraulic cylinder or screw-operated loading device with a rigid fixture and a calibrated force-measuring system,
- An alternative test apparatus capable of applying load in a manner consistent with the

intent of (a) or (b).

7.3 One of the following test fixtures shall be used for cyclic testing:

(a) Servo-hydraulic testing machine operating at a constant rate of displacement of the movable crosshead or a constant rate of loading with calibrated force- and deflection-measuring devices capable of capturing load-deflection readings in accordance with the cyclic loading procedure,

(b) Servo-controlled hydraulic cylinder with a rigid fixture operating at a constant rate of displacement or a constant rate of loading with calibrated force- and deflection-measuring devices capable of capturing load-deflection readings in accordance with the cyclic loading procedure,

(c) An alternative test apparatus capable of applying cyclic load in a manner consistent with the intent of (a) or (b).

8. Test Specimen

8.1 The number of tested specimens shall comply with the requirements of Section K2.1 of AISI S100.

8.2 The connection assembly shall consist of the interference connector device and the *steel deck* or *steel deck-slab*.

8.2.1 The interference connector device shall meet the specified material standard, manufacturer's tolerances and be installed in accordance with the manufacturer's instructions.

8.2.2 When used in the connection assembly, welding consumables, screws, bolts, threaded rods, rivets, and other fasteners shall meet the applicable material standard.

8.3 The connection assembly shall be installed in *steel deck* or *steel deck-slabs*.

8.3.1 *Steel deck* shall be within manufacturer's standard production tolerances.

8.3.2 Structural concrete used in assemblies shall be prepared and cured in accordance with standard construction practice in accordance with Chapter 19 of ACI 318 in the United States and Mexico, and in accordance with CSA-A23.1 and A23.2 in Canada.

8.4 Nonstructural insulating or cellular concrete used in assemblies shall be prepared and cured in accordance with applicable standards and manufacturer's instructions, or in the absence of instructions, representative of the end use conditions.

9. Test Setup

9.1 The test configuration shall be representative of the intended use in the installed application. The *steel deck* specimens shall be of adequate size for the test fixture to resist the loads applied to the *steel deck* or *steel deck-slab* and connection assembly without influencing the strength of the connection assembly being tested.

9.1.1 The attachment of the specimen to the test fixture shall be outside the area of the profiled *steel deck* that is affected by the connection assembly. The fixture shall not restrain the *steel deck* webs from expanding across the width of the deck in a manner that is not representative of the intended use.

9.1.2 The attachment of the specimen to the test fixture shall be outside of the area of the *steel deck-slab* that is affected by the failure mode of the connection assembly. Supplemental reinforcement is permitted in the concrete to resist cracking and provide restraint of the concrete around the steel deck that would be representative of the intended use.

9.1.3 When applicable to the installation, group effects, spacing and edge distance of connection assemblies shall be investigated in *steel deck* without concrete fill or concrete filled *steel deck-slabs* to establish the interaction of the connection assemblies or minimum connection spacing to eliminate interaction effects.

9.2 Application of Loads

9.2.1 Normal Loading. The load, $\pm P_z$, shall be applied normal to the plane of the *steel deck* or *steel deck-slab* as shown in Figure 9-1a for profiled *steel deck-slabs* or Figure 9-1b for *steel deck* with $\alpha = 0^\circ$.

9.2.2 Shear Loading. The load, $\pm P_x$, or $\pm P_y$, shall be applied parallel and as close as possible to the plane of the *steel deck* or *steel deck-slab* as shown in Figure 9-2. The following three loading conditions shall be investigated:

- (a) Load applied perpendicular to ribs,
- (b) Load applied parallel to ribs, and
- (c) Load applied at an angle, θ , for a combined perpendicular and parallel condition.

9.3 Combined Normal and Shear Interaction Loading. The load, $\pm P_\alpha$, shall be applied at angle α as shown in Figure 9-3. The following loading conditions shall be investigated:

- (a) Load applied perpendicular to ribs at a combined normal and shear interaction angle, α ,
- (b) Load applied parallel to ribs at a combined normal and shear interaction angle, α , and
- (c) Load applied at an angle, θ , at a combined normal and shear interaction angle, α , at a combined perpendicular and parallel condition.

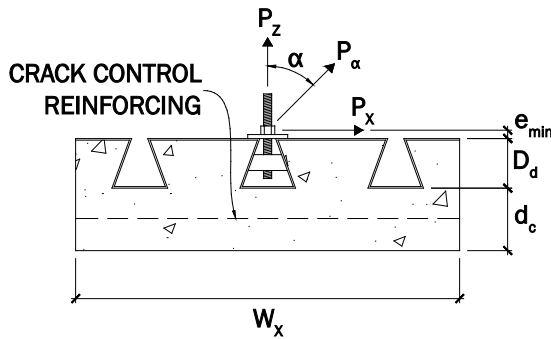

Figure 9-1a
Profile View Test Setup
Steel Deck-Slab

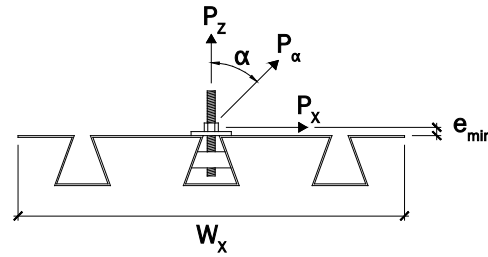

Figure 9-1b
Profile View Test Setup
Steel Deck

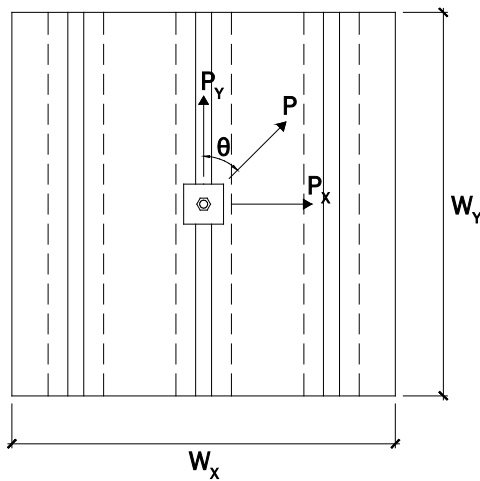

Figure 9-2
Plan View Test Setup
for Steel Deck or
Steel Deck-Slab

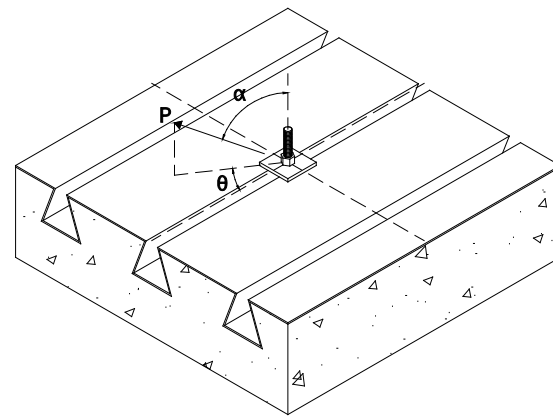

Figure 9-3
Isometric View Test Setup
for Combined Shear and Tension-
Compression Interaction
for Steel Deck or Steel Deck-Slabs

9.4 Deflection measurement. Measurements shall be made from the nearest practical location on the connector to the *steel deck* or *steel deck-slab*. The measurements shall be taken in a location to minimize the effect of distortion in the area proximate to the connection. It is permitted to use multiple measurements to account for distortions during loading of the test specimen.

9.5 Pre-Qualified Test Setups. Any test setups that meet the requirements of Section 9 are permitted. Appendix A contains test setups that meet Section 9 requirements.

10. Test Procedure

10.1 An initial applied preload is permitted but is not required.

10.2 Monotonic Loading. Monotonic loading is permitted to determine elastic load-deformation and strength for shear, tension, compression and combined loading direction performance of interference connection assemblies.

10.2.1 When manually controlled and instrumented tests are performed instead of using computerized control and a computer-based data acquisition system, loading shall be applied in load increments of approximately one-tenth of the estimated maximum load. When the maximum estimated load is approached, smaller increments are permitted. Each load increment shall be maintained as required to obtain readings before proceeding with the next increment. Loading shall continue until the load cannot be maintained, or until one or more connections have failed.

10.2.2 When a computerized test system is used with displacement or load rate control and electronic data acquisition capability, the duration of the test shall not be less than 1 minute.

10.2.3 It is acceptable to pause the loading to take deflection readings or for other purposes required to run the test.

10.2.4 A minimum of 10 load-deformation readings shall be taken prior to the estimated ultimate load for a monotonic test.

10.3 Cyclic Loading. Quasi-static reverse cyclic load tests are permitted to determine load-deformation and the shear, tension, and compression strengths.

10.3.1 It is permissible to use FEMA 461 for displacement or force controlled cyclic loading protocols. Other recognized and approved reverse cyclic loading sequences are permitted in lieu of FEMA 461.

10.3.2 Representative static load tests shall be performed to determine the load and displacement at ultimate load to establish the increments of the cyclic load pattern in accordance with the selected procedure.

10.3.3 A minimum of 10 load-deformation readings shall be taken on each ascending and descending load cycle to establish the load deflection curve.

11. Data Evaluation

11.1 Evaluation of the test results and the determination of the available strength (allowable strength for ASD and design strength [resistance] for LRFD and LSD) shall be in accordance with Section K2.1 of AISI S100.

11.1.1 When cold-formed steel or the interference connection controls the mode of failure, the statistical data in AISI S100 Table K2.1.1-1 under the category “Other Connectors or Fasteners” shall be used unless the primary contributing factor to the mode of failure is directly related to a listed connection type. If the connection strength is controlled by the failure of the concrete fill, the appropriate statistical data for “Connections for Structural Concrete” shall be used.

11.1.2 When concrete strength controls the mode of failure, the connection strength shall be adjusted in accordance with Eq. 11-1 for tested concrete strength above the specified design strength. Adjustment for tested concrete strength below the design strength shall not be permitted.

$$P_t = P_u (f'_c \text{ design} / f'_c \text{ test})^{1/2} \quad (\text{Eq. 11-1})$$

Alternate adjustment methods for concrete strength are acceptable when derived from

testing a range of concrete strengths to develop a connection-specific adjustment method.

User Note:

Concrete compression cylinders should be cast at the same time as the slab in case compression tests are needed to determine concrete strength, f_c' .

When concrete strength controls, the use of Equation 11-1 is assumed to be conservative. The allowance of alternate adjustment methods is intended to provide a means of adjustment when a range of concrete strengths is used to establish the relationship between the strength of the concrete and the connection strength.

11.2 No test result shall be eliminated unless a valid rationale for its exclusion can be given.

12. Report

12.1 The test report shall include a description of the tested specimens, including a drawing(s) detailing all pertinent dimensions.

12.2 The test report shall include installation instructions or a description of the installation method and process to verify quality assurance of the installation as applicable to the type of connection assembly tested.

12.3 The test report shall include the material specification and measured mechanical properties of the *steel deck* materials used in the test.

12.4 The test report shall include the specification of the connector component materials used in the test.

12.5 When concrete fill is used, the mix design and compressive strength at the time of testing shall be included in the test report.

12.6 The test report shall include a detailed drawing of the test setup, depicting location and direction of load application, location of displacement instrumentation and their point of reference. Additionally, photographs are permitted to supplement the detailed drawings of the test setup.

12.7 The test report shall include a description of the test method and loading procedure used, and rate of loading or rate of motion of the crosshead movement.

12.8 The test report shall include individual load-deformation values and curves, plotted directly, or as reprinted from data acquisition systems.

12.9 The test report shall include individual and average maximum test load values observed, description of the nature, type and location of failure exhibited in each test, and a description of the general behavior of each test configuration during load application. Additionally, photographs are permitted to supplement the description of the failure mode(s).

Appendix A, Pre-Qualified Test Setups for Specific Cases

The test assemblies included in Appendix A shall be considered acceptable within the application limitations for each test configuration. The use of test assemblies and methods that are not included in this Appendix are permitted, provided they meet the requirements of the Standard.

A1 Beam Style Steel Deck Test Configuration

A1.1 Geometry and properties of the test specimen shall meet the following conditions:

- (a) *Restrained connection* or *unrestrained connection* assemblies,
- (b) *Steel deck* or *steel deck-slabs*,
- (c) Beam span, L , as shown in Figure A1-1a is representative of the intended use,
- (d) Connection locations defined by a and b in Figure A1-1a are representative of the intended use,
- (e) The *steel deck* width is not less than 3 ribs wide, unless a narrower *steel deck* is representative of the use. Wider assemblies are acceptable.
- (f) The *steel deck* is attached to the resisting supports with the fastener type and attachment pattern representative of the intended use. It is permitted to use the weakest attachment type and pattern for all conditions.
- (g) The *steel deck* is permitted to be trapezoidal or re-entrant profile. (Re-entrant profile is shown in the figures.)

A1.2 Figures A1-1a and A1-1d depict the application of loading and indicate the locations of the reactions for a single span configuration, and Figures A1-1b and A1-1c depict the angles of the applied load with respect to the *steel deck*. The compression reactions shown for the *steel deck* or *steel deck-slab* in Figures A1-1a and A1-1d are permitted to be tension reactions below the *steel deck* or *steel deck-slab*.

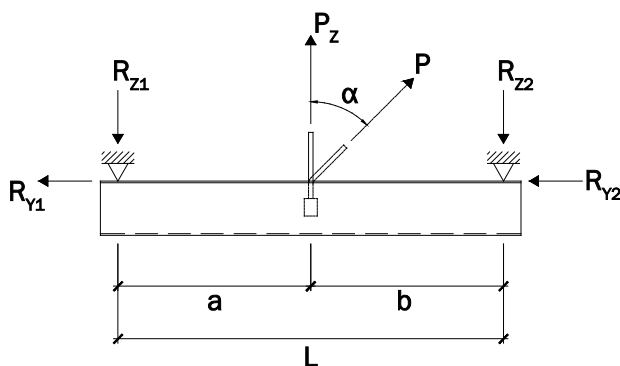

Figure A1-1a
Side View of Applied Load
and Reactions

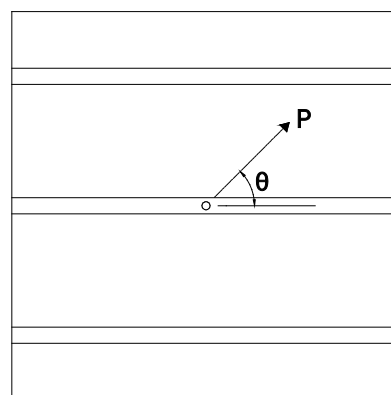

Figure A1-1b
Plan View (Top) of
Applied Load

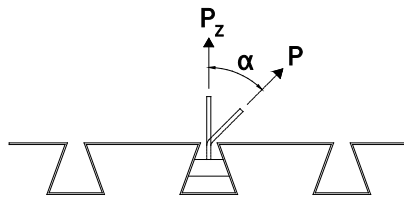

Figure A1-1c
Beam Configuration Cross-Section
at Connector

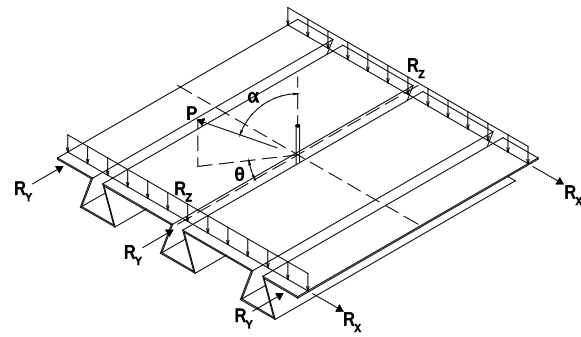

Figure A1-1d
Beam Configuration Isometric View

Figure A1-2 shows a typical representative configuration that uses two cross beams at the reactions to restrain the *steel deck* or *steel deck-slab* with the load applied normal to the plane of the *steel deck* or *steel deck-slab*. In lieu of clamping beams shown in Figure A1-2a or A1-2b, similar assemblies are permitted to be configured to test the connections in orientations other than normal to the *steel deck* or *steel deck-slab* by using connections to reaction beams that are representative of the intended use to secure the *steel deck* or *steel deck-slab* resisting the uplift and shear.

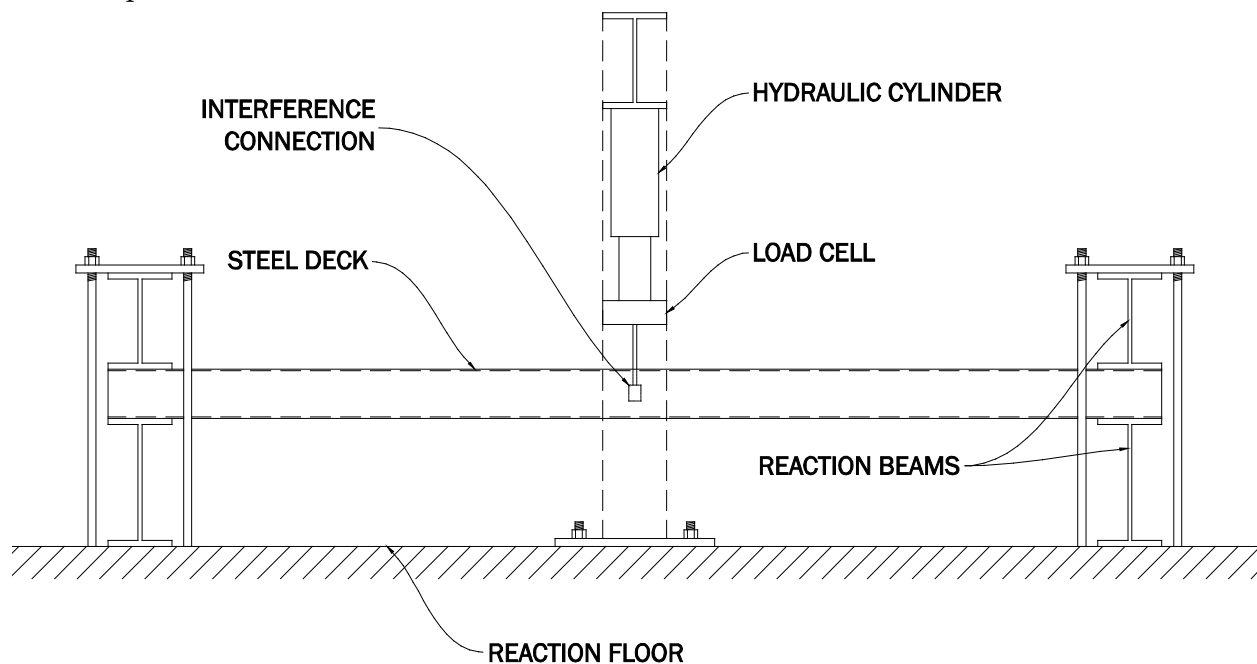

Figure A1-2a Simple Beam Test on Reaction Floor

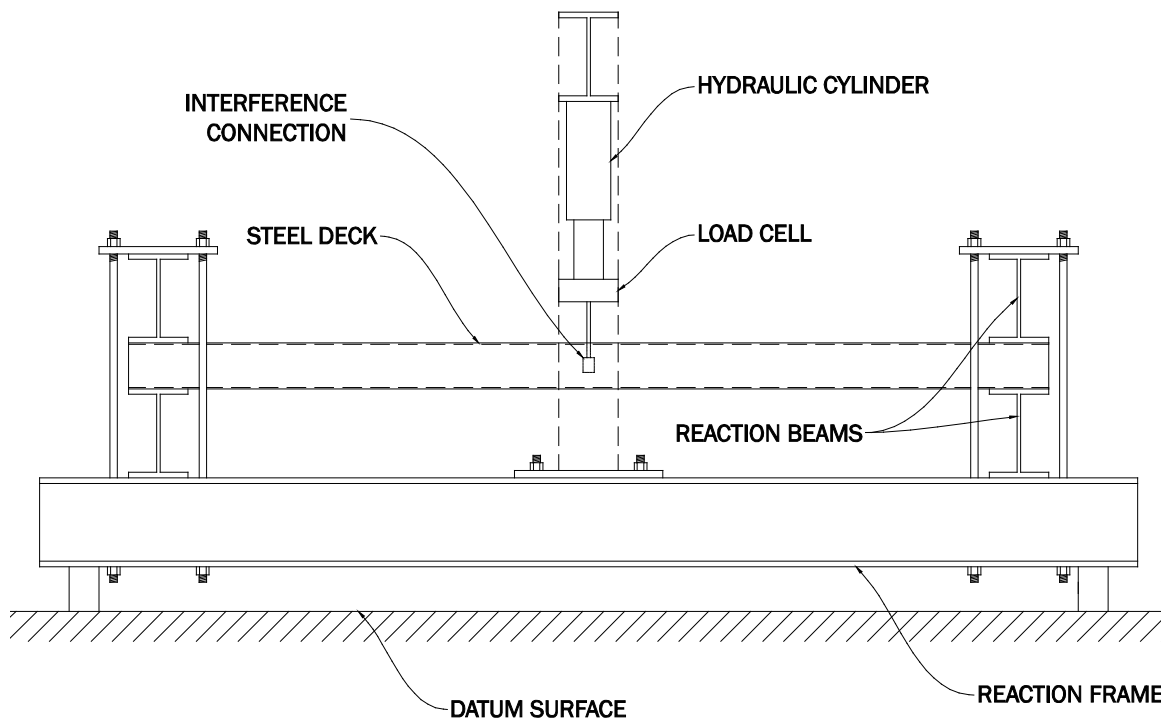

Figure A1-2b Simple Beam Test on a Reaction Frame

A2 Small Size Steel Deck Configuration

A2.1 Geometry and properties of the test specimen shall meet the following conditions:

- (a) *Restrained connection* or *unrestrained connection* assemblies,
- (b) The *steel deck* is permitted to be trapezoidal or re-entrant profile (re-entrant profile shown in Figures A2-1a and A2-1b),
- (c) *Steel deck* width, w_T , is a minimum of 3 ribs wide unless a narrower *steel deck* is representative of the use. Wider assemblies shall be acceptable,
- (d) *Steel deck* length, w_L , is not less than 12 inches, and,
- (e) The load is applied normal to the plane of the *steel deck*.

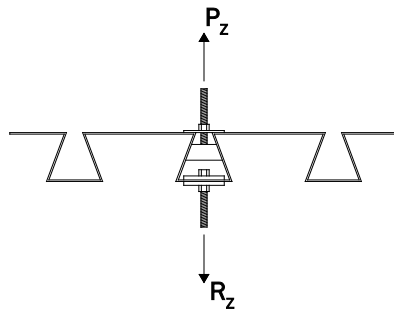

Figure A2-1a
Profile View of Resisting
Anchorage for Steel Deck
(Without Concrete Fill)

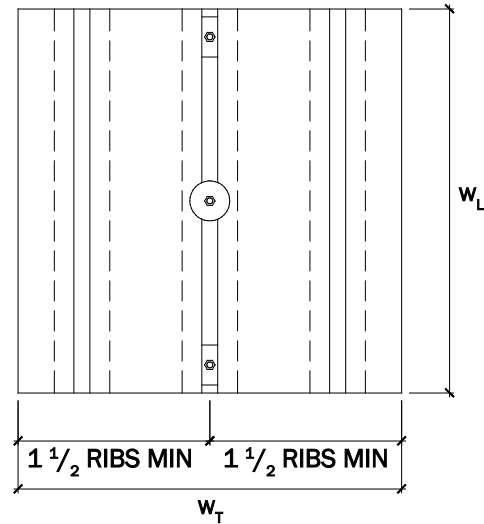

Figure A2-1b
Plan View (Top) of Resisting
Anchorage for Profiled Steel Deck
(Without Concrete Fill)

A3 Small Size Steel Deck-Slabs

A3.1 Geometry and properties of the test specimen shall fall within:

- Concrete depth, $d_c \geq 2$ in. (50.8 mm) for general use. A shallower depth is permitted to replicate the depth of the intended end use of the configuration,
- Width of test specimen perpendicular to the ribs of the *steel deck*, $w_T \geq 24$ in. (609.6 mm) but not less than 3 ribs wide,
- Length of test specimen parallel to the ribs of the *steel deck*, $w_L \geq 24$ in. (609.6 mm),
- Normal weight or lightweight structural concrete or insulating concrete, and
- The *steel deck-slab* profile is permitted to be trapezoidal or re-entrant. (Re-entrant profile shown in the figures.)

A3.2 Figures A3-1a through A3-1f show representative assemblies restrained to the datum surface with typical load applications at various load angle configurations. It is permitted to restrain the slabs to the datum surface similar to that shown in Figures A3-1a and A3-1b and to apply the load at the appropriate orientation (angle) for the test configuration. *Steel deck-slabs* are permitted to be restrained by clamping, thru-bolting, or using cast-in anchors provided the restraint system is outside the area of influence as specified in Section 9.1.2.

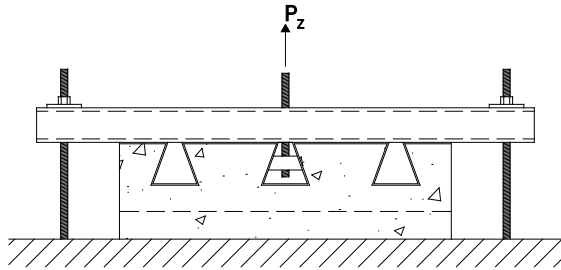

Figure A3-1a
Profile View Loading
Normal to Steel Deck-Slab

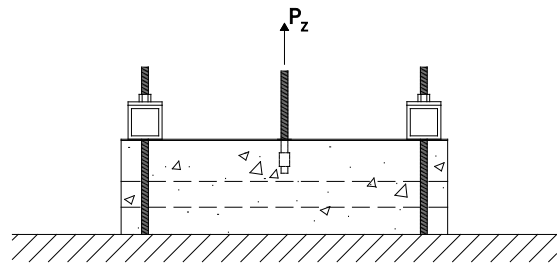

Figure A3-1b
Side View Loading
Normal to Steel Deck-Slab

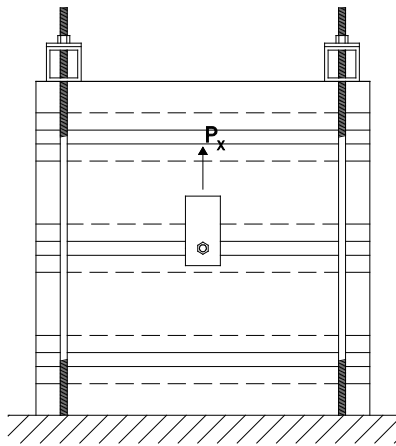

Figure A3-1c
Plan View In-Plane Shear

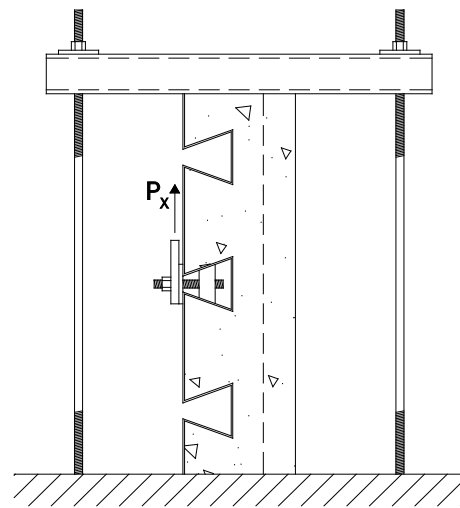

Figure A3-1d
Profile View In-Plane Shear

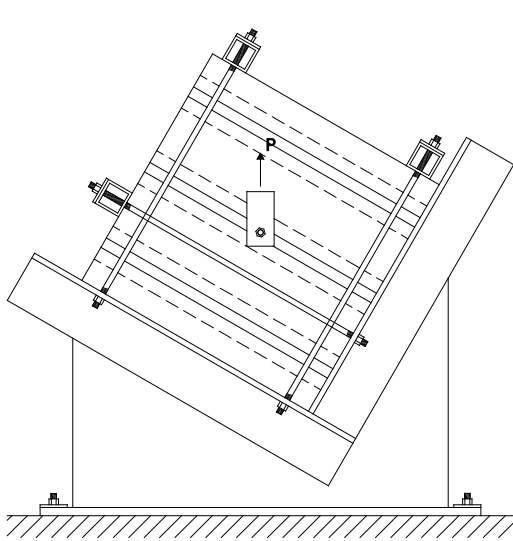

Figure A3-1e
Plan View of
In-Plane Shear Interaction

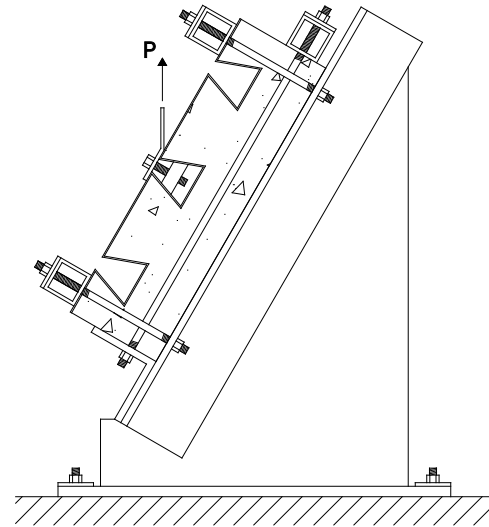

Figure A3-1f
Profile View of
Out-of-Plane Interaction

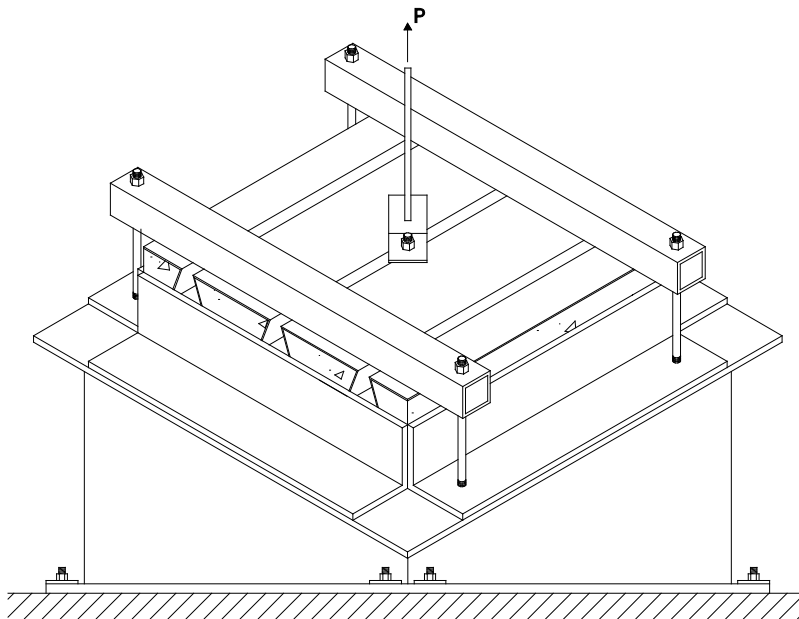

Figure A3-1g
Isometric View of Combined Interaction

**COMMENTARY ON AISI S922-19
TEST STANDARD FOR DETERMINING THE STRENGTH AND STIFFNESS OF BEARING-FRICTION INTERFERENCE CONNECTOR ASSEMBLIES IN PROFILED STEEL PANELS**

1. Scope

The intent of this Standard is to provide guidance for testing connections to *steel deck* or *steel deck-slabs* that involve bearing, interference, expansion or clamping action, and that may utilize mechanical fasteners or welds to restrain the *steel deck* or *steel deck-slab* from transverse expansion. The use of expansion or clamping action is a widely accepted method of attachment used by post-installed expansion (wedge) anchors in concrete that rely on the mechanically generated friction between the anchor and the concrete to keep the anchor from slipping out, thereby transferring load from the anchor to the surrounding concrete. Connector assemblies may include as a component of the assembly common connection components such as screws, bolts, nuts, washers, threaded rods, rivets, clinches, or welds.

This Standard is not intended for connections that derive their primary strength from common mechanical connection types such as screws, bolts, rivets, clinch connections or welds that would fall under other test methods such as AISI S905.

The following Figures C-1-1 and C-1-2 depict examples of the types of connector assemblies that are intended to be covered by the scope of this Test Standard for both concrete-filled *steel deck-slabs* and *steel deck* without concrete fill. The depiction of these devices is not intended to limit the scope of the devices included, but rather to provide examples of the concept of a connector that uses a combination of bearing in one or more directions of loading in combination with friction in other directions of loading.

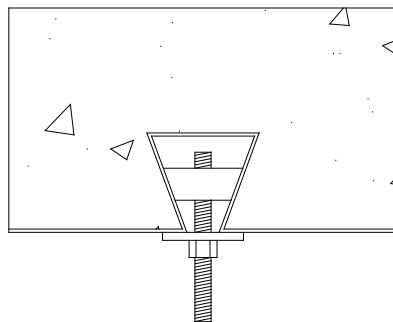

**Figure C-1-1a
Wedge Connector Assembly
in Re-entrant Steel Deck-Slab**

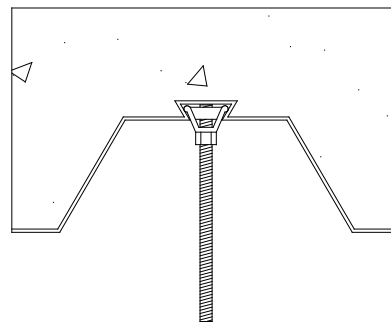

**Figure C-1-1b
Clip-Wedge Connector Assembly
in Re-entrant Stiffener Rib**

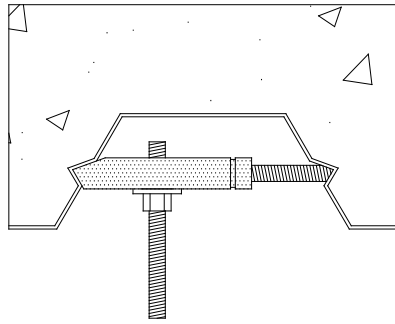

Figure C-1-1c
Extending Connector Assembly
in Stiffener Ribs

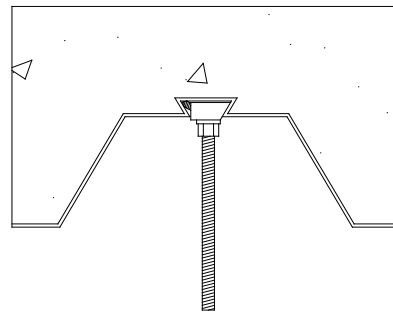

Figure C-1-1d
Wedge Connector Assembly
in Re-Entrant Stiffener Rib

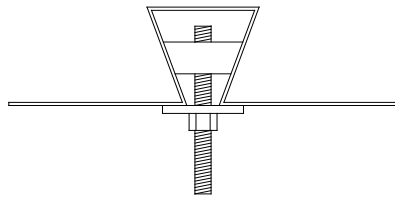

Figure C-1-2a
Wedge Connector Assembly
in Re-Entrant Steel Deck

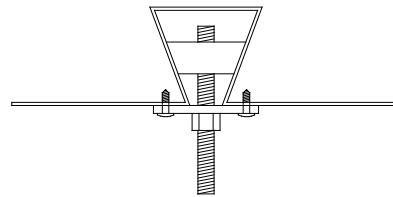

Figure C-1-2b
Restrained Connector Assembly with
Wedge Nut and Restraining Fasteners
in Re-Entrant Steel Deck

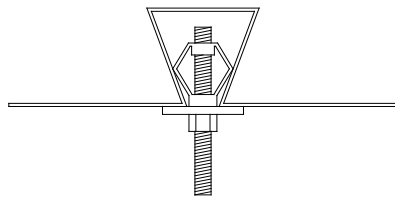

Figure C-1-2c
Expanding Connector
in Re-Entrant Steel Deck

This test method extends the methods originally developed for similar connections by ICC-ES in AC379 and the use of UL203/203A for testing these types of connections. Historic testing under both of these methods is similar to the methods in this Standard. A review is likely to determine that monotonic testing performed under either AC379 or UL203/203A may meet the requirements of this Standard (or at a minimum, the intent of this Standard) and is found to be acceptable. Both AC379 and UL203/203A are monotonic test standards. Therefore, when cyclic testing is required, they will not meet the requirements of this Standard. The analysis of test data taken from testing following AC379 or UL203/203A should be analyzed using Chapter K of AISI S100 to ensure conformance with the current standards.

2. Referenced Documents

AISI S905-17, *Test Standard for Determining the Strength and Deformation Characteristics of Cold-Formed Steel Connections*

ASTM E488/E488M-15, *Standard Test Methods for Strength of Anchors in Concrete Elements*

FEMA 461 (2007), *Interim Testing Protocols for Determining the Seismic Performance Characteristics of Structural and Nonstructural Components*

ICC-ES AC309, *Fastening Systems for Use with Re-Entrant-Type Steel Deck Panel Profiles*

UL 203 (2015), *Standard for Pipe Hanger Equipment for Fire Protection Service*

UL 203A (2015), *Standard for Sway Brace Devices for Sprinkler System Piping*

4. Symbols

| | |
|---------------|--|
| d | Depth of concrete influence due to connection |
| P | Applied load |
| R | Reaction to applied load |
| S | Width or length of area of influence |
| Δ | Relative movement of the deck or connection due to movement (slip) of the connection under load |
| Δ_{ph} | Relative horizontal movement (deformation) of the <i>steel deck</i> due to vertical slip of the connection |
| Δ_{pv} | Relative vertical movement (slip) of the connection to the <i>steel deck</i> |

7. Test Fixture

The test fixtures are not specified in detail in this Standard. It is envisioned that the test fixtures would be relatively rigid compared to the specimen configuration, limiting deflection of the test fixture relative to the tested specimen.

For concrete-filled *steel deck-slabs*, test guidance may be taken from the types of fixtures used for concrete anchor testing in ASTM E488 and UL203/203a. Figures C-7-1 and C-7-2 are examples of possible test fixture configurations. Figure C-7-1 shows a typical reaction fixture attached to a datum surface such as a reaction floor to which both the load frame and test specimen are positively attached. It is also viable to place the test fixture directly on the specimen as shown in Figure C-7-2, which would be similar to the basic fixture in ASTM E488 or UL203 for pulling normal to the plane of the *steel deck-slab* specimen.

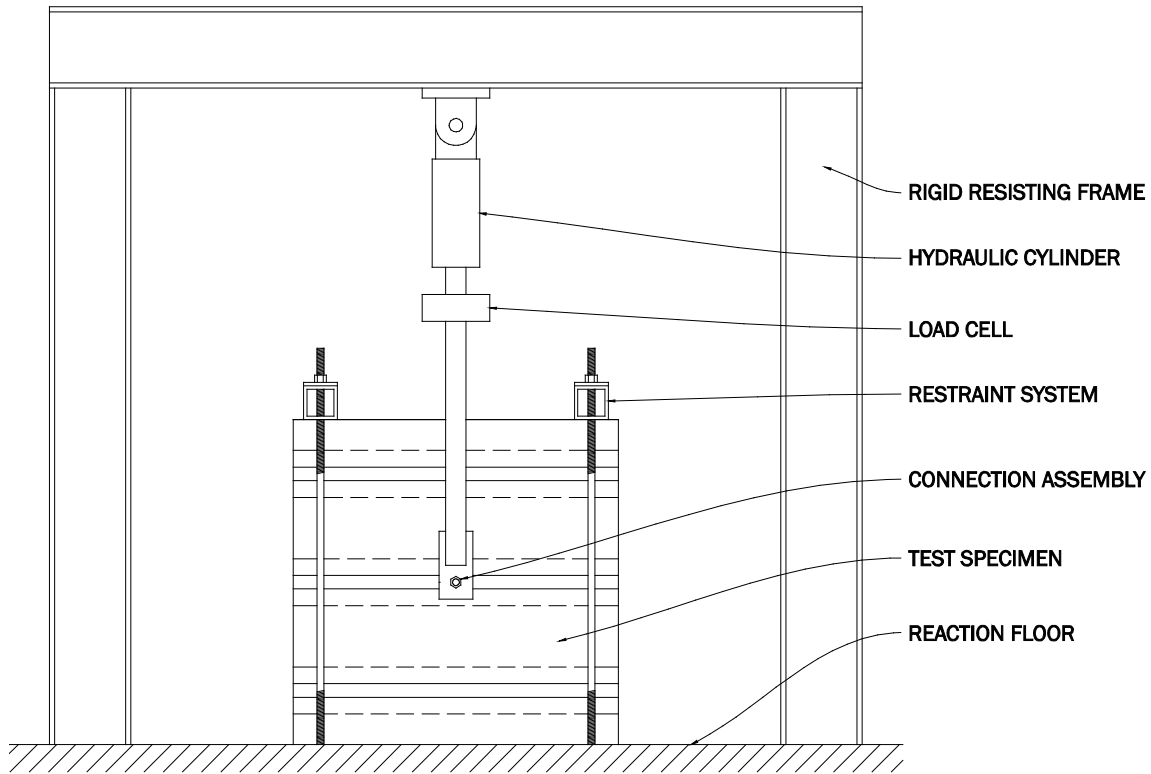

Figure C-7-1 Reaction Frame on Reaction Floor

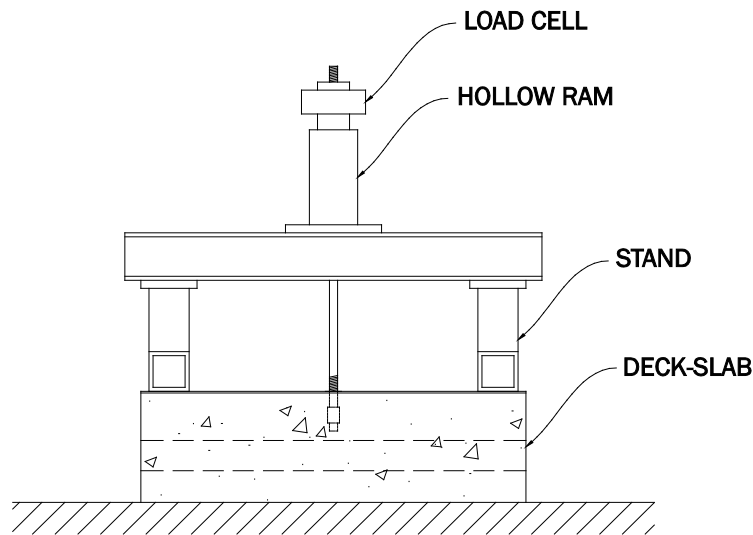

Figure C-7-2 Self-Reacting Fixture

For *steel decks* without concrete fill, small-scale tests may be conducted in a universal tension/compression test machine or using a reaction frame built for this purpose.

8. Test Specimen

Many interference connections and the *steel deck* profiles they are intended to work with tend to be unique in nature. It is therefore critical that the connections be installed following the manufacturer's installation instructions. This is intended to ensure that the connections installed for the tests are representative of the same installation methods used in the field. Many connections include pre-tensioning (tightening) of the connection for proper installation. This should not be confused with pre-loading prior to starting the test.

The Standard allows for the use of nonstructural insulating concrete. This may be cellular, vermiculite or other material. The Standard indicates that the insulating concrete should be in accordance with the applicable standard, rather than specifying a wide range of potentially applicable standards.

9. Test Setup

9.1 The primary intent of the test setup is to ensure that the configuration is loaded in a manner similar to the expected use. This does not dictate that all test setups need to be the same size as the intended configuration; however, they should be proportioned in a manner such that the failure mode of the connection is not adversely affected by the size of the configuration or that the ultimate load is not increased due to the influence of the configuration size.

9.1.1 For *steel decks* without concrete fill, it is critical for unrestrained connections that the resisting structure of the test fixture does not prohibit the *steel deck* transverse expansion in a manner greater than the intended application of the product. Connections that restrain the *steel deck* in the transverse direction, thereby maintaining the cross-sectional shape of the *steel deck*, may include restraining straps or fasteners as shown in Figure C-1-2b. *Unrestrained connections* in *steel deck* may be subject to transverse deformation as shown in Figure C-9-1a.

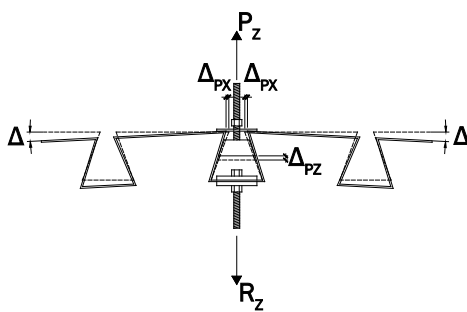

Figure C-9-1a
Unrestrained Connection
Transverse Deformation

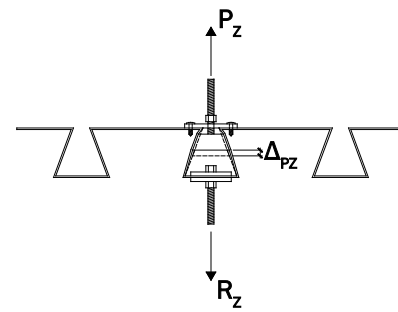

Figure C-9-1b
Restrained Connection
Transverse Deformation

9.1.2 For concrete-filled *steel decks*, it is critical that the reaction surfaces restraining the test specimen be outside the area of influence of the concrete shear cone if concrete will be part of the mechanism of failure. This would be similar to the minimum 4 times

depth requirement considered in ASTM E488 for concrete anchors.

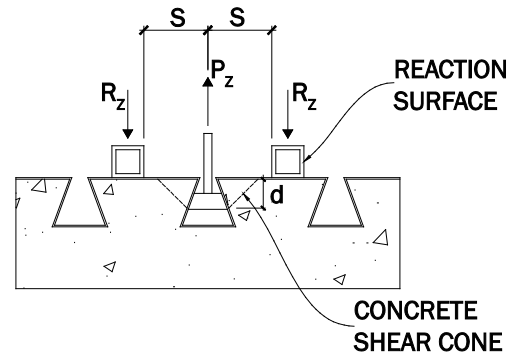

Figure C-9-2 Reaction Restraint Clearance

9.1.3 Investigation of group effects is performed when determination of the minimum spacing to ensure that a connection does not affect the adjacent connection in the rib or to determine the interaction of connections that affect one another is necessary. The interaction effects of anchors installed in concrete is a well understood concept in which to get the full capacity of the anchor they must be spaced such that the shear cones do not intersect. When spaced closer, the strength of the anchors may be reduced. This is of similar concern for interference anchors in *steel deck* with or without concrete fill. Figure C-9-3 depicts the effect of transverse stiffness for an *unrestrained connection* in a *steel deck* without concrete fill. In the absence of an analytical theory to predict this effect, testing on a range of spacings can be performed to develop this interaction or to prove that there is not a minimum spacing for the type of interference connection.

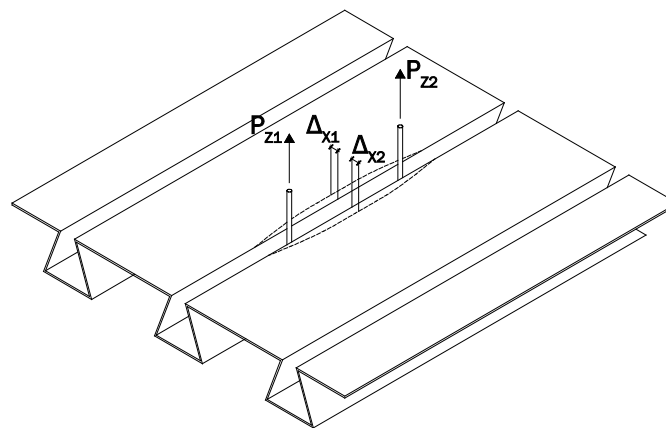

Figure C-9-3 Group Effect of Unrestrained Connections

9.2 The application of loads may be normal to the plane of the *steel deck* in tension or compression, in-plane with the *steel deck* in shear or at any intermediate angle relative to the

plane of the *steel deck*. It is also critical to consider the angle of the load relative to the ribs of the *steel deck* with respect to being relatively parallel with the ribs, transverse to the ribs, or at an intermediate angle.

9.2.1 Load normal to the plane of the *steel deck* would be most analogous to a typical hanging load from a floor or flat roof *steel deck*. For many applications, this may be the extent of the required testing if the connections are only intended to support loads hanging below a horizontal or nearly horizontal steel floor or roof deck.

9.2.2 Shear loading in the plane of the *steel deck* is intended to test for pure-shear without any out-of-plane loading. An example of this would be the restraint of the top track of a cold-formed steel partition wall bearing on the floor below, in which the top slip-track is braced laterally by the interference connection but is not subject to any hanging tension load from the wall.

9.3 For most bracing conditions the load is applied at an angle relative to the plane of the *steel deck* in combination to loading parallel with the ribs, perpendicular to the ribs or an intermediate angle to the ribs. This is the most robust loading condition and will likely require a wide range of test configurations to develop a complete understanding of how an interference connection performs over the range of anticipated angles. A minimum number of intermediate angles is not mandated because of the unique nature of any individual connection type. It would be reasonable to consider 2 intermediate angles between the orthogonal directions as a bare minimum to develop an interaction understanding. Many interference connections may exhibit a much stronger and weaker direction relative to the ribs, thus the need for additional tests to understand this interaction may be required.

10. Test Procedure

10.1 When a preload is desired or deemed necessary, the impact of preload on the load deflection should be considered. For a connection that tends to exhibit a significant linear elastic load-deflection segment prior to nonlinear (inelastic) load-deflection, the effect of preload will typically have little impact on the overall load-deflection relationship as shown in Figure C-10-1a as the preload is increased to point 1 and returns to zero at point 2 following the linear elastic load-deflection path. For a connection that has an initial nonlinear portion of the load deformation curve prior to a significant linear elastic portion, a preload may be desired to measure the load-deflection relative to the permanent set after the preload is removed (as shown in Figure C-10-1b) as the preload climbs the load-deflection curve to point 1 and then when released, descends following the linearly elastic load-deflection line to point 2. For a connection that tends to have a nonlinear (inelastic) load-deflection characteristic over the entire range, the impact of preload may have a significant impact on the overall load-deflection relationship (as shown in Figure C-10-1c) as the preload climbs the load deformation curve to point 1 and then when released, holds the permanent set dropping to point 2. When preload is used, it is advisable to run pretests to understand the effect of preload on the load-deflection relationship either to limit the preload to minimize the impact, or understand how to adjust the load-deflection curve to account for permanent set due to preload.

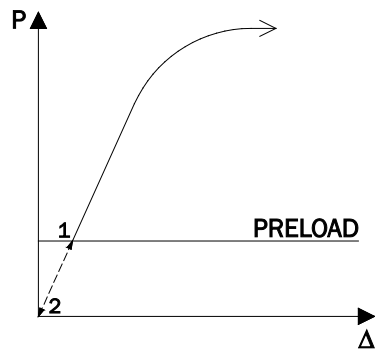

Figure C-10-1a
Linear Elastic

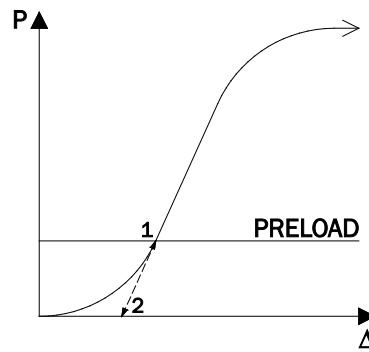

Figure C-10-1b
Eliminating Initial Slip

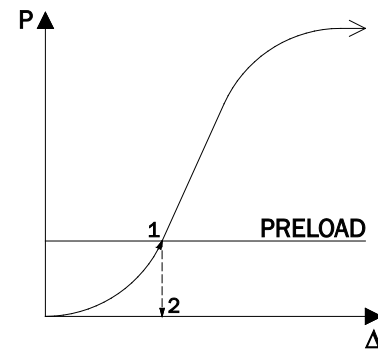

Figure C-10-1c
Non-Linear With
Permanent Set

10.2 This Standard includes monotonic loading to provide an economical method to test connections that are intended for load combinations that are primarily gravity or wind. Monotonic loading may be appropriate for loads that are primarily seismic in nature when the mechanism related to the ultimate strength of the connection is a positive mechanical connection or a weld. Examples of positive mechanical connections would be direct bearing, bolts, screws, or rivets. Connections that rely on clamping or an expanding force against the surfaces thereby generating friction in order to provide restraint generally would not be considered positive mechanical connections.

10.3 Cyclic testing is appropriate to develop the strength of a connection to resist all load combinations. Cyclic loading is included in this Standard primarily for resisting seismic loads that would not fall under the monotonic loading conditions. This is critical for connections that are not positive mechanical connections and thus could experience a significantly degraded ultimate strength due to multiple load reversals. Cyclic testing would also be the basis for more complex systems that provide force protection of other components through energy dissipation characteristics of the connection assembly.

This Standard encourages the use of FEMA 461 through the permissive language that this method is always acceptable. FEMA 461 provides guidance for testing structural and non-structural components using either deflection-controlled or force-controlled cycles. Force-controlled cycles may be better for relatively stiff connections than displacement-controlled cycles when the deflections are relatively small compared to the load.

The use of FEMA 461 is encouraged for the development of new connection types. The Standard does not prohibit the use of other cyclic loading procedures that have been historically used. Care should be taken when selecting a cyclic loading protocol to ensure that it is appropriate for this type of connection.

11. Data Evaluation

This test method is suitable for both the evaluation of a single test configuration by running multiple tests of that configuration or running an array of test configurations for comparison with an analytic theory to describe the performance over a range of tests. Both are fully

enabled through AISI S100 Chapter K. When analyzing an array of test configurations, it is critical that in addition to the boundaries an adequate number of intermediate tests be run to understand the behavior and any significant change in behavior between the bounds. The Standard does not mandate a minimum number of intermediate tests because of the significant variety of connections that makes it difficult to define a minimum that would be applicable to all types of connections.

The use of AISI S100 Chapter K is suitable to determine the nominal strength and appropriate resistance factor or safety factor for design. Chapter K is not intended to be used to develop an understanding of the energy dissipation characteristics of a connection. Guidance may be taken from FEMA 461 for analyzing testing when the intent is to understand the energy dissipation characteristics of a connection that influence the estimated seismic load on the connection.

12. Report

The manufacturer's installation instructions are a critical component of the test report. By nature this category of interference connections tends to be proprietary and the proper understanding of the installation may not be generally understood. The manufacturer's instructions are therefore a critical element in ensuring proper installation and inspection of the connections.

Commentary to Appendix A, Pre-Qualified Test Setups for Specific Cases

A1 The beam style test method is considered to be the most representative for *steel decks* without concrete fill because it provides the most representative lab assembly relative to the intended use. This method is also suitable for concrete-filled *steel decks*. However, it may not provide any additional benefit over the small size concrete-filled *steel deck-slab* configuration in Section A3.

The loads may be applied at any angle relative to the plane of the *steel deck*. This test is ideally suitable for developing the interaction of multiple connections in the same rib and the effects of end restraints to the supports. For wedge-type connections that flex the ribs open in re-entrant *steel deck* and the continuous keys of trapezoidal *steel deck* in the transverse direction as shown in Figure C-9-3, it is generally a reasonable engineering prediction that a test at the center of the *steel deck* with the least transverse restraint due to supports would be valid for locations closer to the supports. Conversely, it would not be reasonable to assume that the ultimate load of a test close to the supports with transverse stiffness influenced by the attachment to supports would be equal to a test in the center of the *steel deck* away from the supports. This may not be the case for highly constrained re-entrant keys such as those shown in Figure C-1-2b.

A2 The small-scale test configuration without concrete fill is intended for loads that are applied normal or close to normal to the plane of the *steel deck*. It would be reasonable to assume that most flat roof structures with a roof pitch less than 1:12 would meet this requirement. This test is intended to provide a low-cost conservative method to validate the strength of connections for hanging loads from steel roof deck. The small size test is generally considered to be conservative compared to the beam style test. The short length of the specimen flexes open in the weak direction without the restraint of adjacent webs as shown in Figures C-9-1a and C-9-1b. The washers used for the restraining bolts should be such that they provide minimal influence on the transverse stiffness of the *steel deck*.

A3 The small-size test configuration of concrete-filled *steel deck* is intended to provide a relative economical configuration that is suitable for load applied at all angles relative to the plane of the *steel deck*. Reinforcement in the concrete section above the interaction height of the connection assembly is recommended to restrain the concrete from splitting in a manner that would be unrepresentative of the typical interior application of the connectors in a *steel deck-slab*. It is acceptable to use unreinforced concrete when this is more representative of the intended use, or when unreinforced effects relative to a slab edge are being investigated.

The minimum test specimen size was derived from test standards for cast-in-place or post installed anchors in concrete in UL 203/203a and ASTM E488. Both of these standards have a proven track record of providing reliable test results for anchors in concrete, but do not address some of the unique issues of interference connectors in *steel deck* covered in this Standard.



Sci